

DINGS[™]
Precision Motion Specialist

STEPPER LEAD SCREW LINEAR ACTUATOR PRODUCT CATALOG



DINGS' Stepper Lead Screw Linear Actuators come in eight sizes, ranging from a square frame 14 mm (NEMA 6) to 86 mm (NEMA 34).

There are four form factors available – External, Non-Captive, Electric Cylinder (Captive) and Kaptive.

DINGS' provides over 20 different travels/step of lead screws ranging from 0.00006 inch [.0015mm] to 0.005 inch [.127mm]. Micro-stepping can be used for finer resolution and various step motor angle options are available.

Max. 2,400N linear thrust force can be generated and brake / teflon coating / encoder / manual knob options also can be chosen.

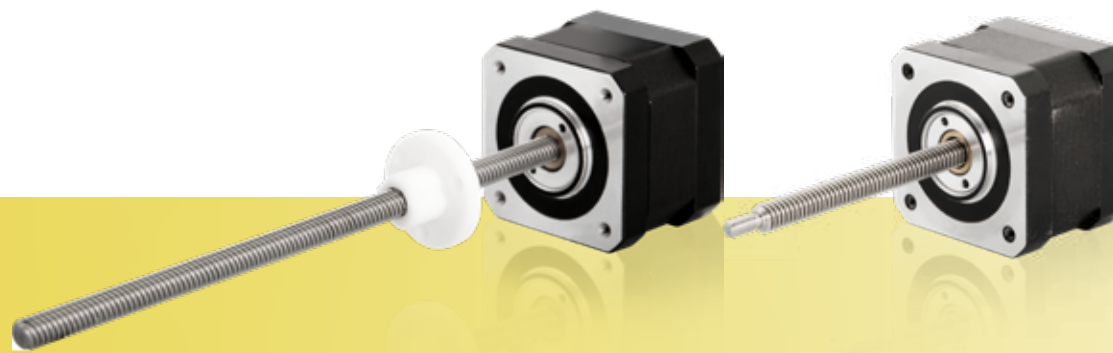

Stepper Lead Screw Lin

CONTENTS

Part number construction

Lead screw code selection

Product selection guide

Technology overview

General specifications

Size 6 · 14 mm

Size 8 · 20 mm

Size 11 · 28 mm

Size 14 · 35 mm

Size 17 · 42 mm

Size 23 · 57 mm

Size 24 · 60 mm

Size 34 · 86 mm

Accessories and options

Installation guide

Trouble shooting



Piezo Actuator

Part Number Construction

17N 2 1 15 K 4 - 101.6 T M S EK2 - 001



① Motor Size

| | | | | | | | | |
|-------------------|----|----|----|----|----|----|----|----|
| Motor Size (mm) | 14 | 20 | 28 | 35 | 42 | 57 | 60 | 86 |
| Motor Size (NEMA) | 6 | 8 | 11 | 14 | 17 | 23 | 24 | 34 |

② Linear Actuator Type

E = External Linear Actuator
N = Non-Captive Linear Actuator
C = Electric Cylinder (Captive) Linear Actuator
K = Kaptive Linear Actuator

③ Motor Step Angle

2 = 2 Phase with 1.8°
4 = 2 Phase with 0.9°
5 = 5 Phase with 0.72°

④ Motor Length

1 = Single Stack
2 = Double Stack
3 = Triple Stack

⑤ Rated Current/Phase

XX = X.X (A)/Phase

⑥ Lead Screw Code

Please refer to lead screw code selection table

⑦ Number of Lead Wires

4 = 4 Flying Leads
6 = 6 Flying Leads
8 = 8 Flying Leads

⑧ Lead Screw Length / Stroke

XXX = XXX mm Lead screw length
[For External Linear / Non-Captive Linear]
XXX = X.XX inch Stroke
[For Electric Cylinder (Captive) / Kaptive Linear]

⑨ Lead Screw Surface Treatment

T = Teflon Coating
S = Standard Grease

[Note]

-Screw lead <0.6mm : standard grease
-Screw lead >0.6mm : standard grease or teflon coating

⑩ End Machining

M = Metric
U = UNC
S = Smooth
C = Customize
N = None

⑪ Nut Style

S = Standard Flange Nut
[For External Stepper Lead Screw Linear Actuator]
A = Anti-Backlash Nut
[For External/Non-Captive Stepper Lead Screw Linear Actuator]

⑫ Option

EKX = Encoder [X = Encoder Resolution]
P = Manual Knob
B = Brake
X = Rear Shaft
R = Encoder Ready [Hole and Shaft]
C = Customize
N = No processing at the rear end

⑬ Customer Sequence Number

EXAMPLE

Part Number 17N2115K4-101.6TMSEK22

Description NEMA 17 Non-captive Linear Actuator
2 Phase with 1.8 Degree Step Angle
Single Stack
1.5A/Phase
"K" Lead (0.1"/2.54mm lead)
4 Flying Leads
Screw Length: 101.6mm
Teflon Coated Screw
Metric End Machining
Standard Nut
EK2 Encoder with Single Output, 192 lines

Lead Screw Code Selection

| Lead Code | 1.8 degree motor travel per step inch (mm) | Motor size (mm) | | | | | | | | | |
|-----------|--|----------------------|------------------|-----------------|---------------|-------------------|----------------|------------------|----------------|----------------|------------------|
| | | 14 / 20 | 28 | | | 35 / 42 | | 57 / 60 | | 86 | |
| | | Screw Dia. inch (mm) | | | | | | | | | |
| | | Φ3.5 (0.138") | Φ4.77 (0.188") | Φ5.56 (0.218") | Φ6 (0.236") | Φ6.35 (0.25") | Φ8 (0.315") | Φ9.525 (0.375") | Φ10 (0.394") | Φ12 (0.472") | Φ15.875 (0.625") |
| AL | 0.000063" (0.001588) | | 0.0125" (0.3175) | | | | | | | | |
| AA | 0.00012" (0.003048) | 0.024" (0.6096) | | | | 0.024" (0.6096) | | | | | |
| A | 0.000125" (0.003175) | | 0.025" (0.635) | | | 0.025" (0.635) | | 0.025" (0.635) | | | |
| B | 0.00024" (0.006096) | 0.048" (1.2192) | | | | 0.048" (1.2192) | | | | | |
| D | 0.00025" (0.00635) | | 0.05"* (1.27) | | | 0.05" (1.27) | | 0.05" (1.27) | | | |
| F | 0.0003125" (0.0079375) | | | | | 0.0625"* (1.5875) | | 0.0625" (1.5875) | | | |
| H | 0.000415" (0.010583) | | | | | | | 0.083" (2.1167) | | | |
| J | 0.00048" (0.012192) | | | 0.096" (2.4384) | | 0.096" (2.4384) | | | | | |
| K | 0.0005" (0.0127) | | 0.1" (2.54) | | | 0.1" (2.54)" | | 0.1"* (2.54) | | | 0.1" (2.54) |
| L | 0.000625" (0.015875) | | | | | 0.125" (3.175) | | 0.125" (3.175) | | | 0.125" (3.175) |
| P | 0.000835" (0.021167) | | | | | | | 0.167" (4.2333) | | | |
| Q | 0.00096" (0.024384) | | | 0.192" (4.8768) | | 0.192" (4.8768) | | | | | |
| R | 0.001" (0.0254) | | 0.2" (5.08) | | | 0.2" (5.08) | | 0.2" (5.08) | | | 0.2" (5.08) |
| S | 0.00125" (0.03175) | | | | | 0.25" (6.35) | | 0.25" (6.35) | | | 0.25" (6.35) |
| U | 0.0016665" (0.042333) | | | | | 0.3333" (8.4667) | | | | | |
| V | 0.001875" (0.047625) | | | | | | | 0.375" (9.525) | | | |
| W | 0.00192" (0.048768) | | | | | 0.384" (9.7536) | | 0.384" (9.7536) | | | |
| X | 0.002" (0.0508) | | 0.4" (10.16) | | | | | 0.4" (10.16) | | | |
| Y | 0.0025" (0.0635) | | | | | 0.5" (12.7) | | 0.5" (12.7) | | | 0.5" (12.7) |
| Z | 0.005" (0.127) | | | | | 1.0" (25.4) | | 1.0" (25.4) | | | 1.0" (25.4) |
| AF | 0.000059" (0.0015) | 0.0118" (0.3) | | | | | | | | | |
| AB | 0.000197" (0.005) | 0.0394"* (1.0) | | | 0.0394" (1.0) | 0.0394" (1.0) | 0.0394" (1.0) | | | | |
| G | 0.000394" (0.01) | 0.0787" (2.0) | | | | 0.0787" (2.0) | 0.0787" (2.0) | | 0.0787" (2.0) | 0.0787" (2.0) | |
| M | 0.000787" (0.02) | 0.1575" (4.0) | | | | | 0.1575" (4.0) | | | | |
| T | 0.001575" (0.04) | 0.3150" (8.0) | | | | | 0.3150" (8.0) | | | | |
| E | 0.000985" (0.025) | | | | 0.1969" (5.0) | | 0.1969" (5.0) | | | 0.1969" (5.0) | |
| C | 0.00197" (0.05) | | | | | | 0.3937" (10.0) | | 0.3937" (10.0) | 0.3937" (10.0) | |
| I | 0.00394" (0.1) | | | | | | | | 0.7874" (20.0) | | |
| N | 0.000156" (0.00397) | | | | | 0.0313" (0.794) | | | | | |

Note : The data in [] refers to the conversion between metric and imperial systems. When the division is incomplete, rounding is used to retain four significant digits.

Optional left handed rotation with * lead

Product Selection Guide

To reduce complexity and cost of a design, it is important to accurately size a motor / lead screw combination. Belows are a few simple steps in selecting the necessary components for a given application.

■ STEP 1 – CHOOSING A MOTOR SIZE (FORCE REQUIREMENTS)

Here is a general overview of the output thrust vs. motor size:

| | Motor Sizes (mm) | Max Thrust (N) | Recommended Load Limit (N) |
|-----------------------------|------------------|----------------|----------------------------|
| Lead Screw Linear Actuators | 14 | 19 | 15 |
| | 20 | 70 | 45 |
| | 28 | 150 | 140 |
| | 35 | 300 | 230 |
| | 42 | 600 | 230 |
| | 57 | 1300 | 910 |
| | 60 | 1560 | 910 |
| | 86 | 2400 | 2270 |

As the size of the motor increases, the output thrust of the motor correspondingly increases.

■ STEP 2 – CHOOSING A SCREW LEAD (FORCE AND SPEED REQUIREMENTS)

After estimating the required thrust and choosing a motor size that may fit your application, the speed and acceleration of the load must be considered and evaluated to choose an appropriate screw lead.

Due to the nature of lead screws, the output speed and output thrust achievable by a motor/lead screw combination are two proportional. (i.e., increasing the required thrust will lower the achievable speed for a motor/lead screw combination). Therefore, the maximum output force of a system is lowered for applications that requires higher speed.

For complete motor/lead screw selection data, please refer to the speed vs thrust curves for each motor size.

Although these two steps provide a solid foundation in motor/lead screw selection, other variables must also be considered:

- Duty Cycle
- Desired Life of a System
- Environmental Considerations
- Positional Repeatability
- Acceptable Backlash
- Acceleration/Deceleration
- Driver Specifications
- Vertical or Horizontal

Because of the numerous variables involved in motor selection, it is highly recommended for users to proceed with physical testing to accurately determine the motor/lead screw combination required for a given application.

NOTE : Although this section aims to provide a rough guide line to select a motor/lead screw combination that best fits an application, we recommend to contact our application engineering staff or sales representatives for further assistance with the motor selection process.

Technology Overview

One of the most common methods of moving a load from point A to point B is through linear translation of a motor by a mechanical lead screw and nut. This section is here to assist and refresh your understanding of the basic principles of lead screw technology prior to selecting the system that is best for your application.

Some basic design consideration are as follows:

1. What is the load of your system?
2. What is the required linear speed?
3. What is the distance to be travelled?
4. What accuracy does your application require?
5. What is the required time to move from point A to point B?
6. What repeatability does your application require?
7. Horizontal vs vertical orientation?

■ TERMINOLOGY

● LINEAR ACTUATOR TYPES

- A. External Linear
- B. Non-captive
- C. Electric Cylinder (Captive)
- D. Kaptive

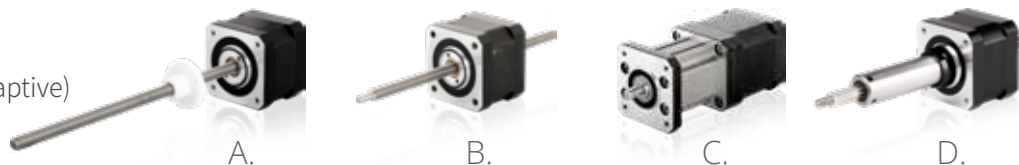

● LEAD

Lead is the axial distance the nut advances on one revolution of the screw. Throughout this catalog, lead will be the term used for revolution a screw as it is the linear distance traveled for one revolution of the screw. The larger the lead, the more linear distance traveled per one revolution of the screw. $\text{Lead} = \text{Pitch} \times \text{screw start}$.

● PITCH

Pitch is the axial distance between threads. Pitch is equal to lead in a single start screw. There may be more than one thread “strand” on a single screw. These are called starts. Multiple start lead screws are usually more stable and efficient at power transmission.

● ACCURACY OF SCREW

Specified as a measurement over a given length of the screw. For example: 0.004 inch per foot. Lead accuracy is the difference between the actual distance traveled versus the theoretical distance traveled based on the lead. For example: A screw with a 0.5 inch lead and 0.004 inch per foot lead accuracy rotated 24 times theoretically moves the nut 12 inches. However, with a lead accuracy of 0.004 inch per foot, actual travel could be from 11.996 to 12.004 inches.

● POSITION TOLERANCE

The approach value between actual distance traveled vs theoretical distance traveled.

● REPEATABILITY

Most motion applications put the most significance on the repeatability (vs accuracy of screw) of a system to reach the same commanded position over and over again.

● HORIZONTAL OR VERTICAL APPLICATION

Vertical orientation applications add the potential problem of backdriving when power to the motor is off and without an installed brake. Vertical application also have an additional gravity factor that must be part of the load/force calculation.

● TOTAL INDICATED RUNOUT

The amount of “wobble” around the centerline of the screw.

Technology Overview

- **VIBRATION AND NOISE**

The hybrid stepper motor's resonance will be occurred when pulse is up to 200PPS. Try starting your acceleration ramp at above these levels. Micro-stepping will also help through these ranges.

- **STATIC LOAD**

The maximum thrust load, including shock load, that should be applied to a non-moving screw.

- **DRIVER**

Stepper motors require some external electrical components in order to run. These components typically include a power supply, logic sequencer, switching components and a clock pulse source to determine the step rate. Many commercially available drives have integrated these components into a complete package. Some basic drive units have only the final power stage without the controller electronics to generate the proper step sequencing.

- **DYNAMIC LOAD**

The maximum recommended thrust load which should be applied to the screw while in motion.

- **HOLDING TORQUE**

When motor is static and rated current is applied to two phase, the stator's holding ability to the rotor.

- **ROTOR INERTIA**

Moment matters when accelerate or decelerate.

- **TRAVEL PER STEP**

The linear travel movement of one full step of the motor.

- **TEMPERATURE RISING**

Motor body's temperature rising after certain periods running and heat exchange with the ambient.

- **RESPONSE PER STEP**

Times takes to complete one step.

- **STEP**

Characteristics of stepper motor that the rotor moves step by step as the stator commutates phase by phase.

- **STEP ANGLE**

Angular movement of every step.

- **PULL OUT TORQUE**

Under certain drive condition (frequency and current), the max load that the motor can drag until missing step.

- **PULL IN TORQUE**

When couples and accelerates, the max load torque (including frictions) that the motor can bear and start.

- **EFFICIENCY**

The ability of a mechanical system to translate an input to an equal output.

- **RESOLUTION**

Incremental linear distance the actuator's (motor) output shaft will move per input pulse.

- **TENSION OR COMPRESSION LOADING**

A load that tends to stretch the screw is called a tension load.

A load that tends to "squeeze" or compress the screw is called a compression load.

Depending on the size of the load, designing the screw in tension utilizes the axial strength of the screw versus column loading.

Technology Overview

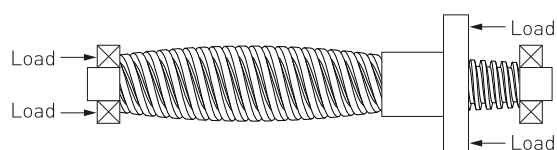

Compression Loading

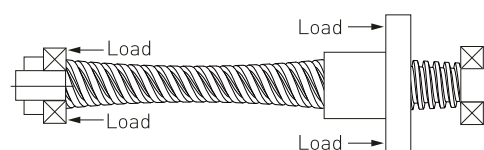

Tension Loading

- **RADIAL LOAD**

A load perpendicular to the screw.

This is not recommended unless additional mechanical support such as a linear guide is used.

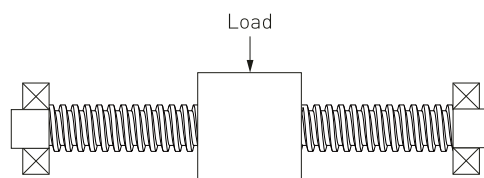

Radial Loading
(Avoid or Minimize)

- **AXIAL LOAD**

A load that exerted at the center line of the lead screw.

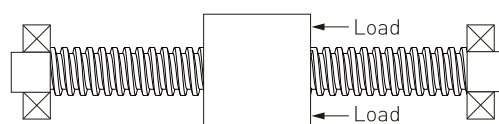

Axial Center Loading
(best)

- **STATIC LOAD**

The maximum thrust load, including shock load, that should be applied to a non-moving screw.

- **DYNAMIC LOAD**

The maximum recommended thrust load which should be applied to the screw while in motion.

- **BACKDRIVING**

Backdriving is the result of the load pushing axially on the screw or nut to create rotary motion. Generally, a nut with an efficiency greater than 50% will have a tendency to backdrive. Selecting a lead screw with an efficiency below 35% may prevent backdriving. The smaller the lead, the less chance for backdriving or free wheeling. Vertical application is more prone to backdriving due to gravity.

- **TORQUE**

The required motor torque to drive just the lead screw assembly is the total of:

1. Inertia Torque
2. Drag Torque (friction of the nut and screw in motion)
3. Torque to move load

- **LUBRICATION**

The nut material contains a self-lubricating material that eliminates the need for adding a lubricant to the system. The Teflon coated screw option also lowers friction and extends life of the system

- **END MACHINING OF THE SCREW (Please refer to 50p)**

Standard metric or English option are available. Custom end machining specifications are also available on request. Please contact your local DINGS' representative.

Technology Overview

● FIXITY

The performance (speed and efficiency) of the screw system is affected by how the screw ends are attached and supported.

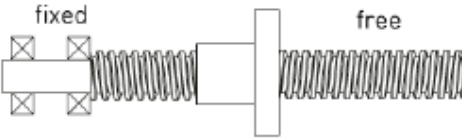
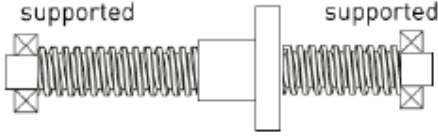
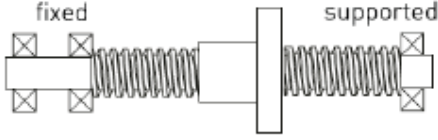
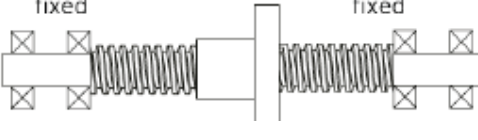
| Type of End Fixity | Relative Rigidity | Critical Speed Factor | Critical Load Factor |
|--|-------------------|-----------------------|----------------------|
|  <p>fixed free</p> | Less Rigid | 0.32 | 0.25 |
|  <p>supported supported</p> | Rigid | 1.0 | 1.0 |
|  <p>fixed supported</p> | More Rigid | 1.55 | 2.0 |
|  <p>fixed fixed</p> | Most Rigid | 2.24 | 4.0 |

● COLUMN STRENGTH

When a screw is loaded in compression, its limit of elastic stability can be exceeded and the screw will fail due to bending or buckling.

● CRITICAL SPEED

Critical speed is the rotational speed of the screw at which the first harmonic of resonance is reached due to deflection of the screw. A system will vibrate and become unstable at these speeds.

Several variables affect how quickly the system will reach critical speed:

1. The lead of the screw
2. The rotational speed
3. End fixity
4. Thrust load
5. Diameter of the screw
6. Tension or compression loading

An example in the figure, it shows the screw rod with a diameter of 19.05mm (0.75inch) and a length of 1778mm (70inch) has a safety factor of $K = 1.25$,

And under the fixed mode of $FS = 0.32$, the critical speed is 187rpm.

Technology Overview

- CRITICAL ROTATION SPEED (RPM) VS. UNSUPPORTED SCREW LENGTH FOR VARIOUS SCREW DIAMETERS (INCH)

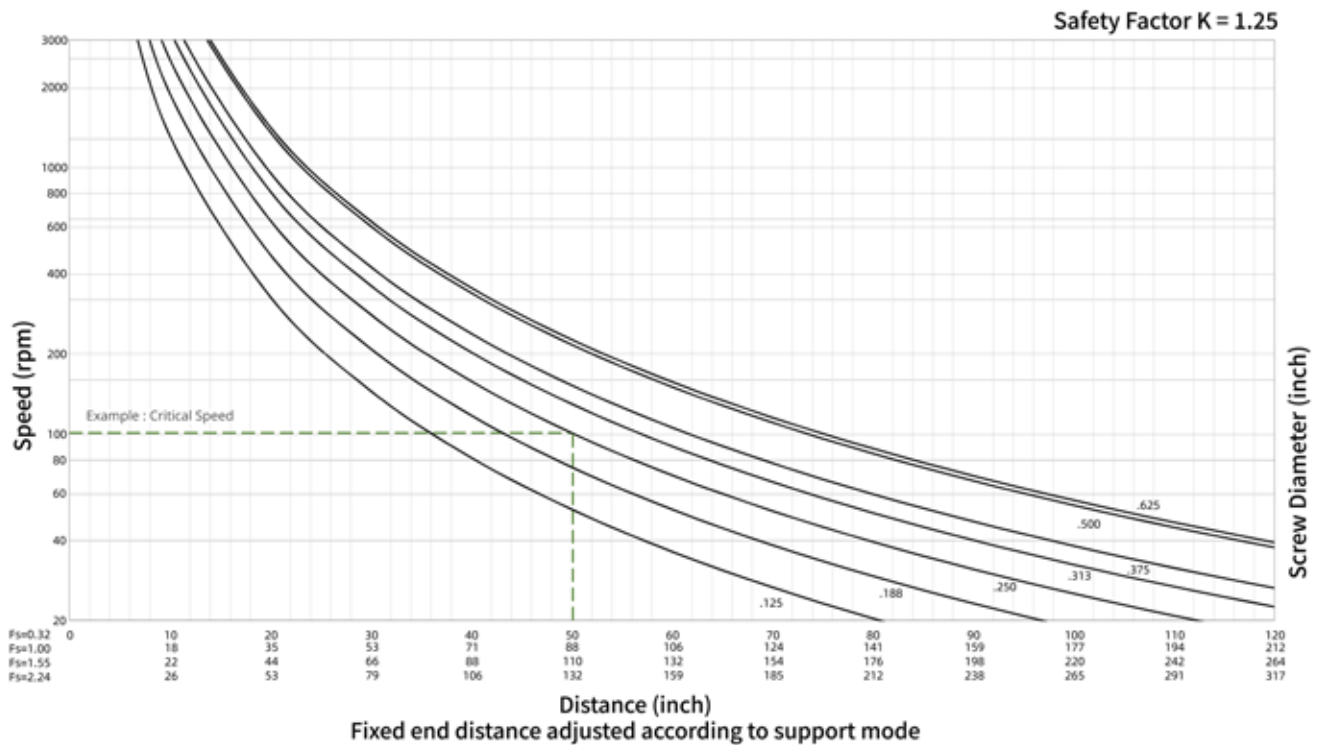

- BACKLASH

Backlash is the relative axial movement between a screw and nut at standstill. It is normal for backlash to increase with wear over time. Backlash compensation or correction can be accomplished through the application of an anti-backlash nut. Backlash is usually only a concern with bi-directional positioning.

Standard Nut

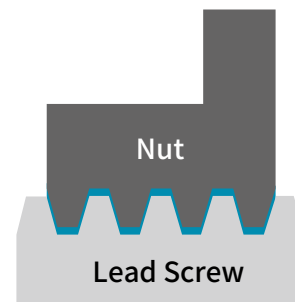

Tension Anti-Backlash Nut

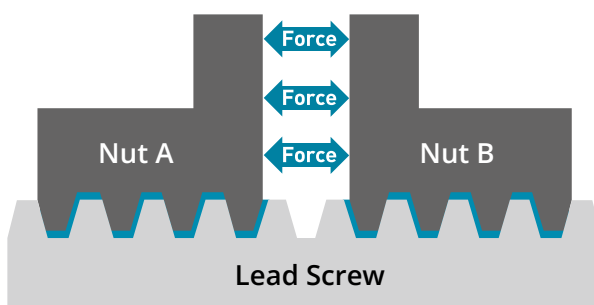

Compression Anti-Backlash Nut

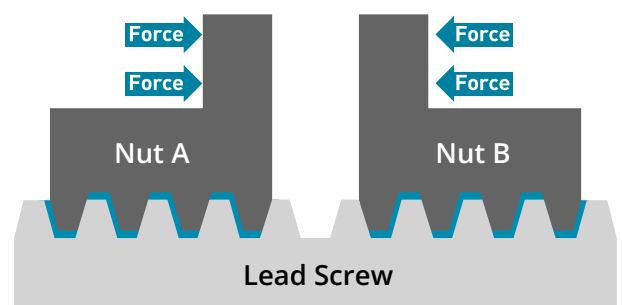

BACKLASH IN BLUE

Technology Overview

Stepper motor : Outlet mode

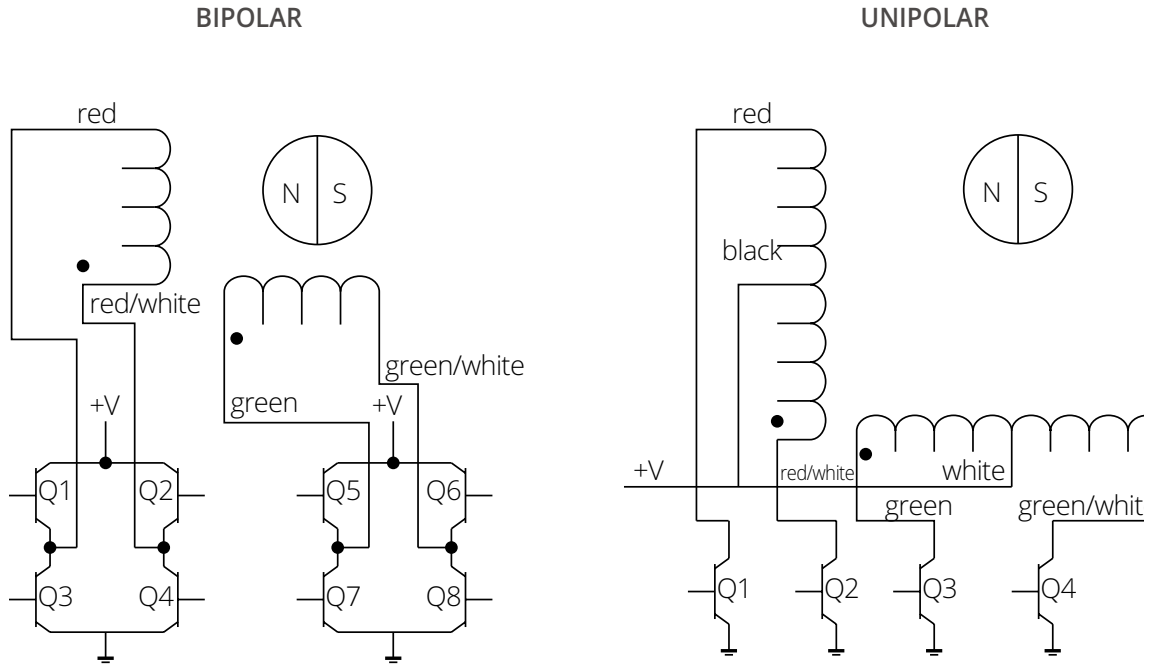

Stepper motor : Step sequence

| | Bipolar | Q2-Q3 | Q1-Q4 | Q6-Q7 | Q5-Q8 | |
|-----------|----------|-------|-------|-------|-------|-------------|
| | Unipolar | Q1 | Q2 | Q3 | Q4 | |
| | Step | | | | | |
| EXTEND CW | 1 | ON | Off | ON | Off | RETRACT CCW |
| | 2 | Off | ON | ON | Off | |
| | 3 | Off | ON | Off | ON | |
| | 4 | ON | Off | Off | ON | |
| | 5 | ON | Off | ON | Off | |

Note: Inserting an off state in phase sequence conversion can achieve half step stepping

General Specifications

All reference to lead screws in this catalog have the following characteristics

| | |
|--|---|
| Lead Screw Material | 303 Stainless precision cold rolled steel |
| Screw Coating | Standard lead screws are coated with a thin layer of grease. Teflon coating is optional. |
| Standard Screw Accuracy (Lead Accuracy) | 0.0071 inch/foot (0.18mm/300mm) |
| Screw Straightnes | 0.15mm/300 mm |
| Screw Efficiency | From 35% to 85% dependent on lead. Also depends on the usage of an anti backlash nut with screw. The larger lead, higher efficiency of the screw. |
| Operating Temperature | -20°to 55°C |
| Storage Temperature | Storage at room temperature with a relative humidity as lower than 75%, clean, well ventilated and free from corrosive gases. |
| Screw Backlash | Generally around 0.01~0.1mm |
| System Backlash | Includes screw, motor, and attached mechanics. This will be the sum of all backlash in customer's motion axis. |
| Nut Material | POM/PBT with Self-Lubricating material. |
| Wear Life of Screw and Nut | Depending on the load, speed, and environment, it is typically millions of cycles. |

NOTE: DINGS' linear system are manufactured from high quality materials. Because of the variable effects of friction, lubrication and cleanliness, an exact life cannot be predicted for a given application.

**FOR MORE INFORMATION, CONTACT YOUR LOCAL
DINGS' REPRESENTATIVE (SEE THE BACK COVER)**

Size 6 (14mm) Series

Size 6 [14mm] Stepper Lead Screw Linear Actuator occupies a mounting footprint of 14mm square and provides 19N of Max. thrust force.



Motor Characteristics

| Motor | Voltage (V) | Current (A _[RMS]) | Resistance (Ω) | Inductance (mH) | Weight (g) | Lead Wire No. | Motor Length (mm) |
|--------|-------------|-------------------------------|----------------|-----------------|------------|---------------|-------------------|
| 6-2103 | 6.6 | 0.3 | 22 | 4.5 | 60 | 4 | 32 |

Note : Motor Insulation Class B, Motor Temperature Rise 80°C, Ambient Temperature -20°C~55°C

Available Lead Screw and Travel per Step

| Screw Dia. (inch) | Screw Dia. (mm) | Lead (inch) | Lead (mm) | Lead Code | Travel Per Step @1.8° (mm)* |
|-------------------|-----------------|-------------|-----------|-----------|-----------------------------|
| 0.138 | 3.5 | 0.0118 | 0.3 | AF | 0.0015 |
| 0.138 | 3.5 | 0.024 | 0.6096 | AA | 0.003048 |
| 0.138 | 3.5 | 0.0394 | 1 | AB* | 0.005 |
| 0.138 | 3.5 | 0.048 | 1.2192 | B | 0.006096 |
| 0.138 | 3.5 | 0.0787 | 2 | G | 0.01 |
| 0.138 | 3.5 | 0.1575 | 4 | M | 0.02 |
| 0.138 | 3.5 | 0.315 | 8 | T | 0.04 |

* Motor wiring and screw lead could be customized according to customer's request

* Value Truncated

* Through axis and fixed axis can only be selected ϕ 2.5mm screw assembly

Dimensional Drawings : External Actuator

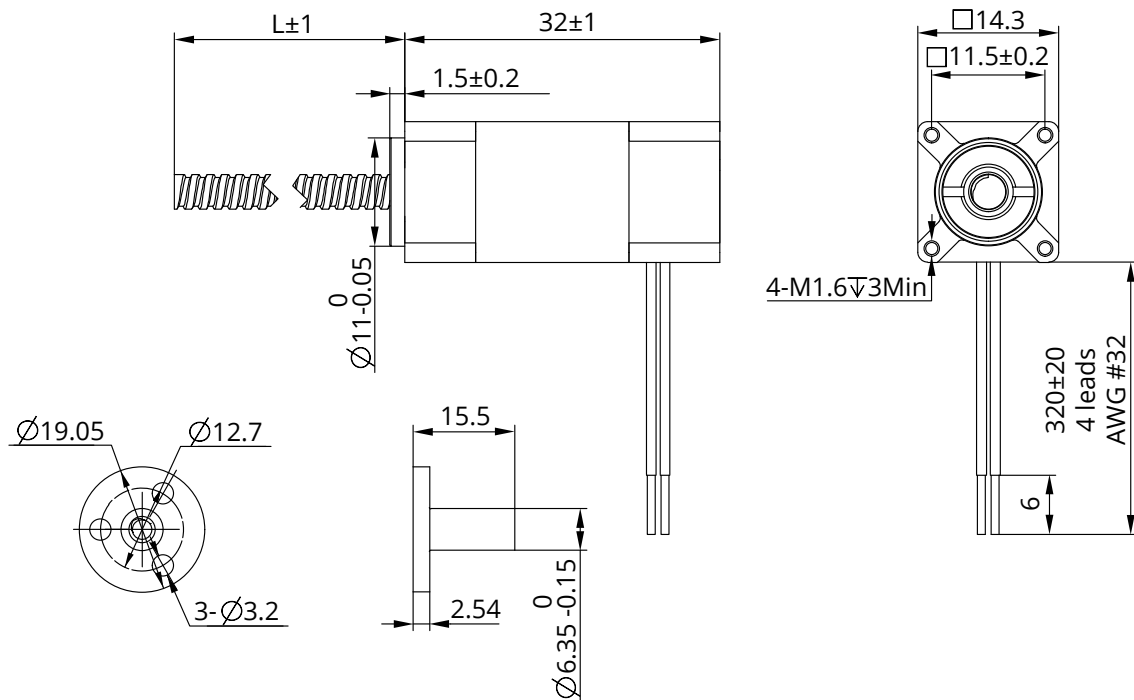

Note : All drawings are 1st Angle Projection - ISO Compliant (3D models available)

Size 6 (14mm) Series

Dimensional Drawings : Non-Captive Actuator

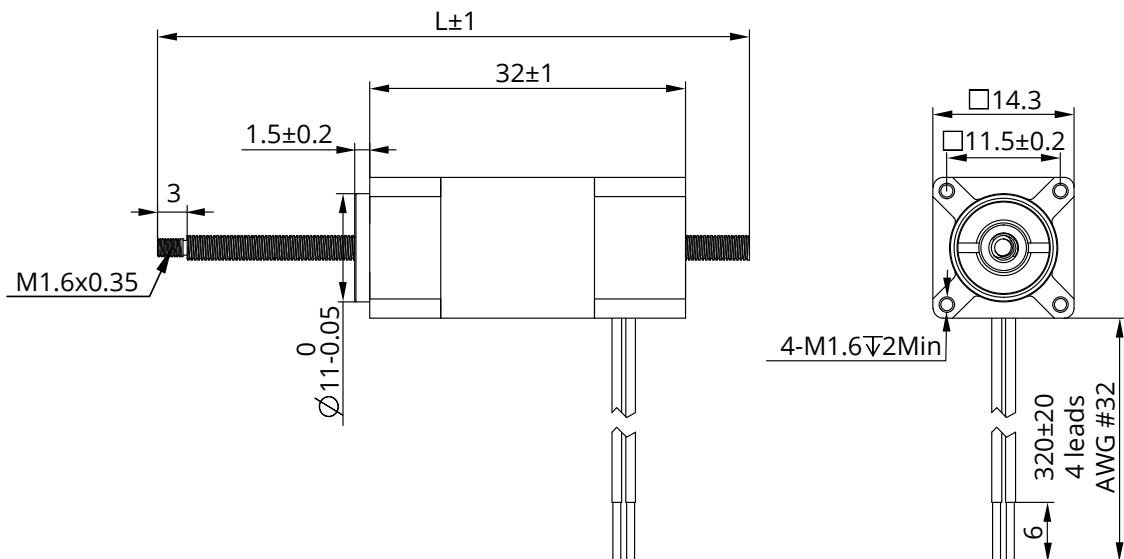

Dimensional Drawings : Captive Actuator

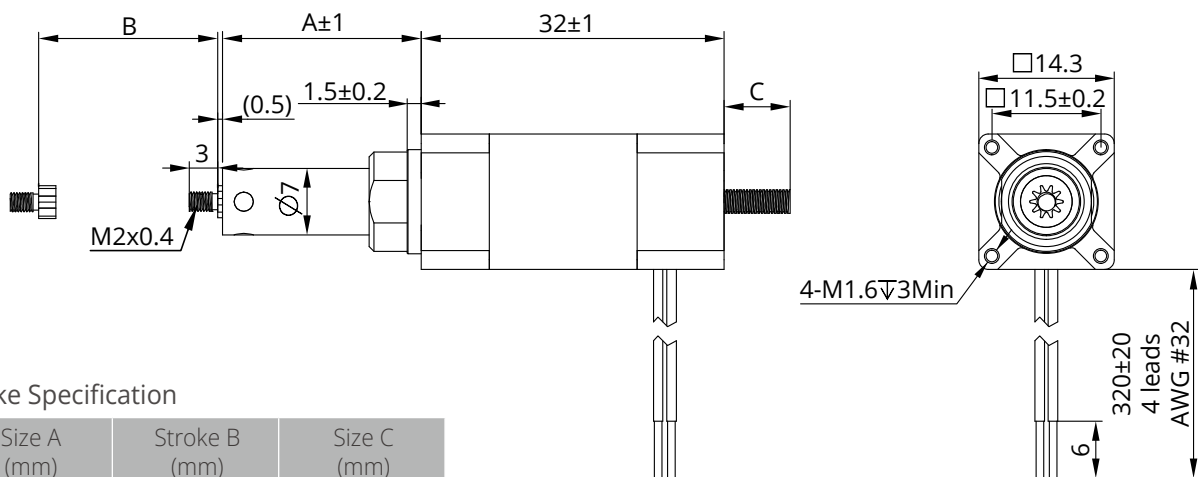

Stroke Specification

| Size A (mm) | Stroke B (mm) | Size C (mm) |
|-------------|---------------|-------------|
| 6 | 5 | 0 |
| 11 | 10 | 0 |
| 16 | 15 | 2 |
| 21 | 20 | 7 |

For stroke customization, please contact DINGS' or local representative.

Size 6 (14mm) Series

Speed Thrust Curves

Size 6 Single Stack Speed Thrust Curves

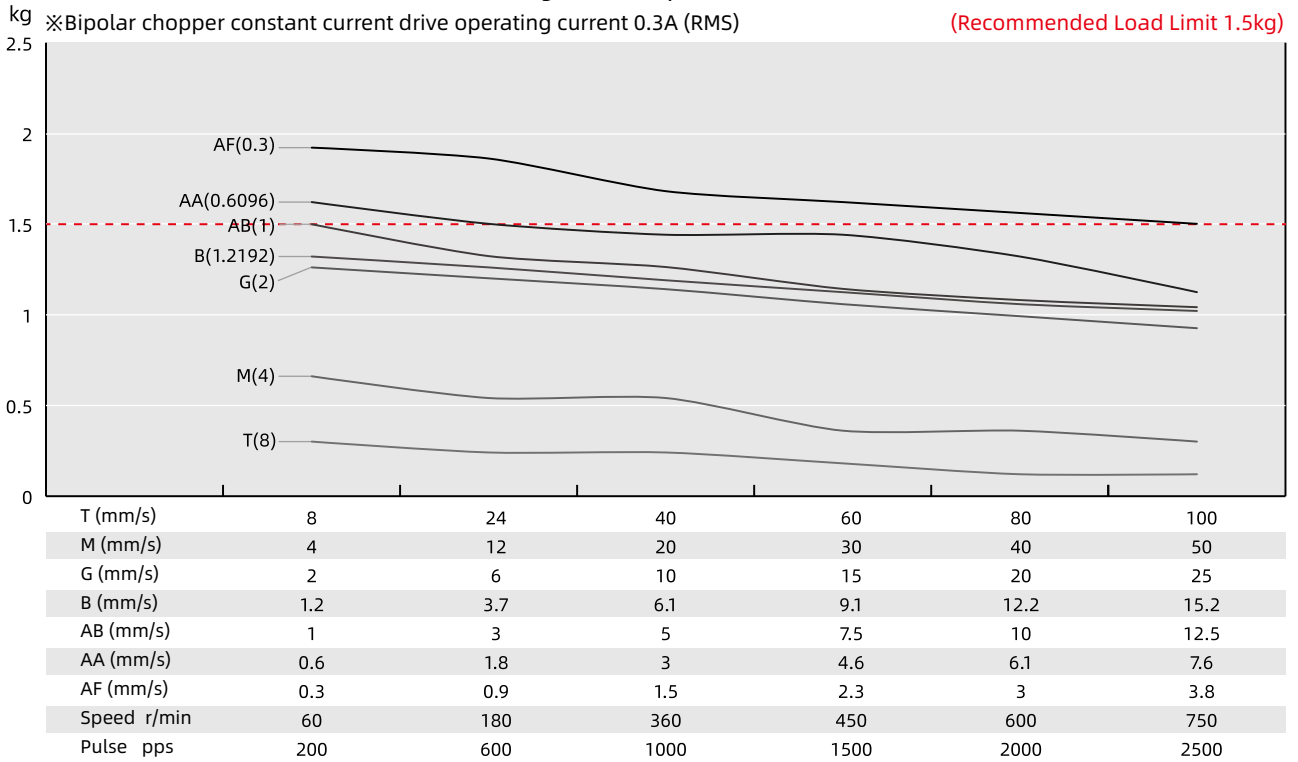

TEST CONDITION

Testing Voltage: 24Vdc, Driver Model: DS-OLS2-FPD bipolar, chopper driver at rated current (rms).
Motor's thrust will be changed with different voltage and driver. 50% thrust margin is recommended.

Size 8 (20mm) Series

Size 8 [20mm] Stepper Lead Screw Linear Actuator unit can be integrated into various applications to provide precise linear positioning while occupying less than 1 in² of mounting footprint and providing up to 45N of continuous thrust.



Motor Characteristics

| Motor | Voltage (V) | Current (A _{RMS}) | Resistance (Ω) | Inductance (mH) | Weight (g) | Lead Wire No. | Motor Length (mm) |
|--------|-------------|-----------------------------|----------------|-----------------|------------|---------------|-------------------|
| 8-2105 | 2.5 | 0.5 | 5.1 | 1.5 | 51 | 4 | 27.2 |
| 8-2205 | 4.4 | 0.5 | 8.8 | 2.7 | 74 | 4 | 38.1 |

Note : Motor Insulation Class B, Motor Temperature Rise 80°C, Ambient Temperature -20°C~55°C

Available Lead Screw and Travel per Step

| Screw Dia. (inch) | Screw Dia. (mm) | Lead (inch) | Lead (mm) | Lead Code | Travel Per Step @1.8° (mm)* |
|-------------------|-----------------|-------------|-----------|-----------|-----------------------------|
| 0.138 | 3.5 | 0.0118 | 0.3048 | AF | 0.0015 |
| 0.138 | 3.5 | 0.024 | 0.6096 | AA | 0.003048 |
| 0.138 | 3.24 | 0.0394 | 1 | AB | 0.005 |
| 0.138 | 3.5 | 0.048 | 1.2192 | B | 0.0061 |
| 0.138 | 3.5 | 0.0787 | 2 | G | 0.01 |
| 0.138 | 3.5 | 0.1575 | 4 | M | 0.02 |
| 0.138 | 3.5 | 0.315 | 8 | T | 0.04 |

* Motor wiring and screw lead could be customized according to customer's request

* Value Truncated

Size 8 (20mm) Series

Dimensional Drawings : Electric Cylinder (Captive) Actuator

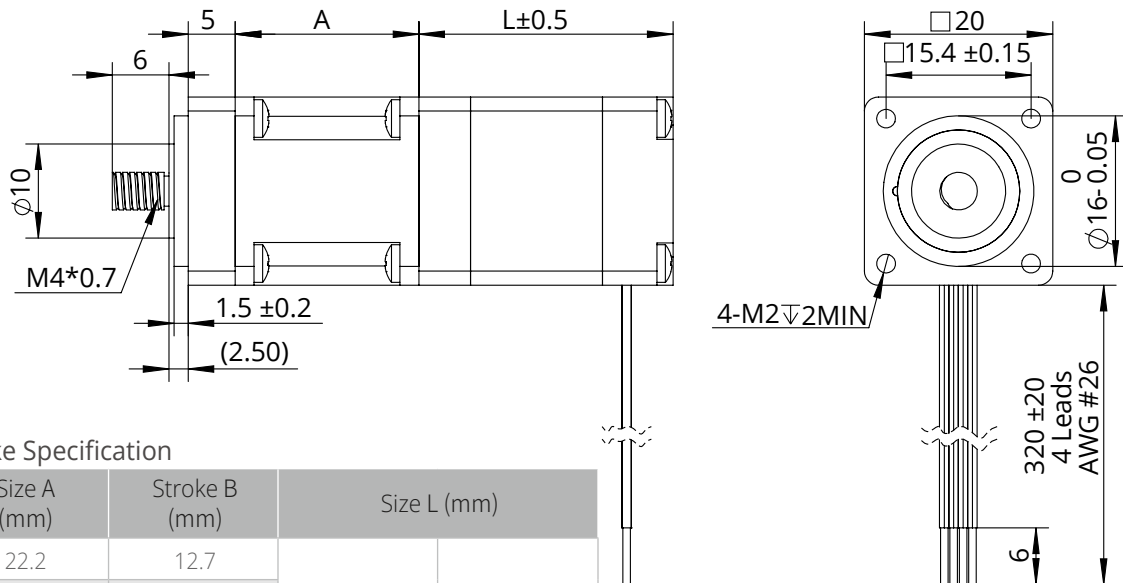

Stroke Specification

| Size A (mm) | Stroke B (mm) | Size L (mm) | |
|-------------|---------------|------------------------------|------------------------------|
| 22.2 | 12.7 | Single stack motor 27.2mm | Double stack motor 38.1mm |
| 28.55 | 19.05 | | |
| 34.9 | 25.4 | | |
| 41.3 | 31.8 | | |
| 47.6 | 38.1 | | |
| 60.3 | 50.8 | | |
| 73 | 63.5 | | |

Dimensional Drawings : Kaptive Actuator

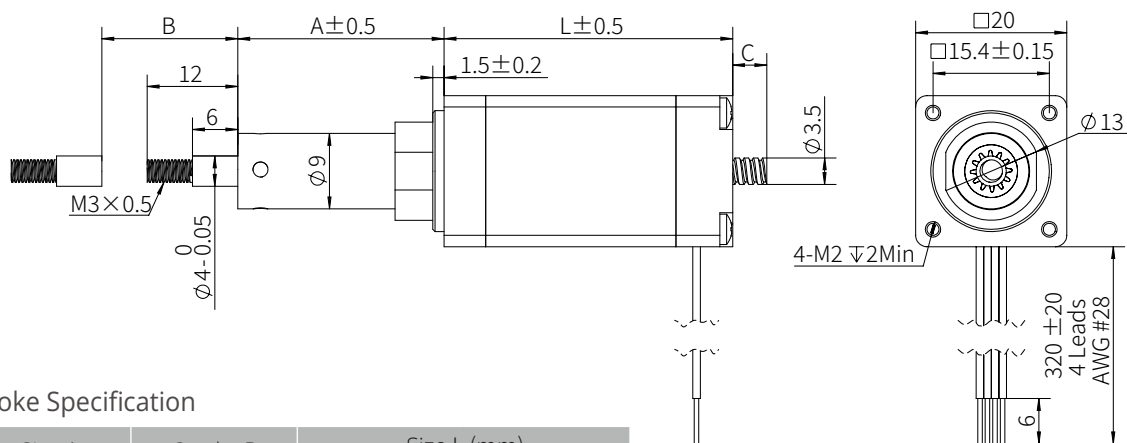

Stroke Specification

| Size A (mm) | Stroke B (mm) | Size L (mm) | |
|-------------|---------------|-------------|--------|
| | | L=27.2 | L=38.1 |
| 10.9 | 9 | 0 | 0 |
| 14.6 | 12.7 | 3.5 | 0 |
| 20.8 | 19.05 | 9.5 | 0 |
| 27.3 | 25.4 | 15.5 | 4.5 |
| 37.3 | 31.8 | 22.5 | 11.5 |
| 40 | 38.1 | 28.5 | 17.5 |

For stroke customization, please contact DINGS' or local representative.

Size 8 (20mm) Series

Speed Thrust Curves

Size 8 Single Stack Speed Thrust Curves

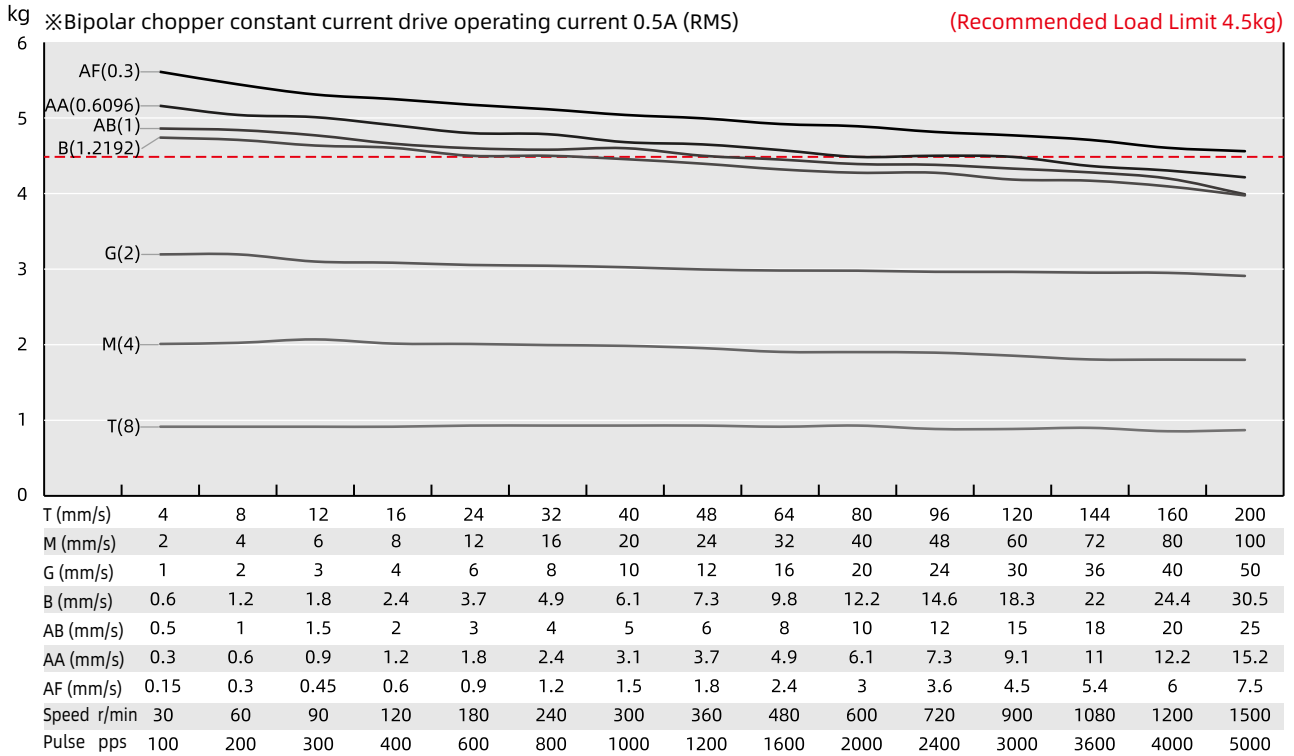

Size 8 Double Stack Speed Thrust Curves

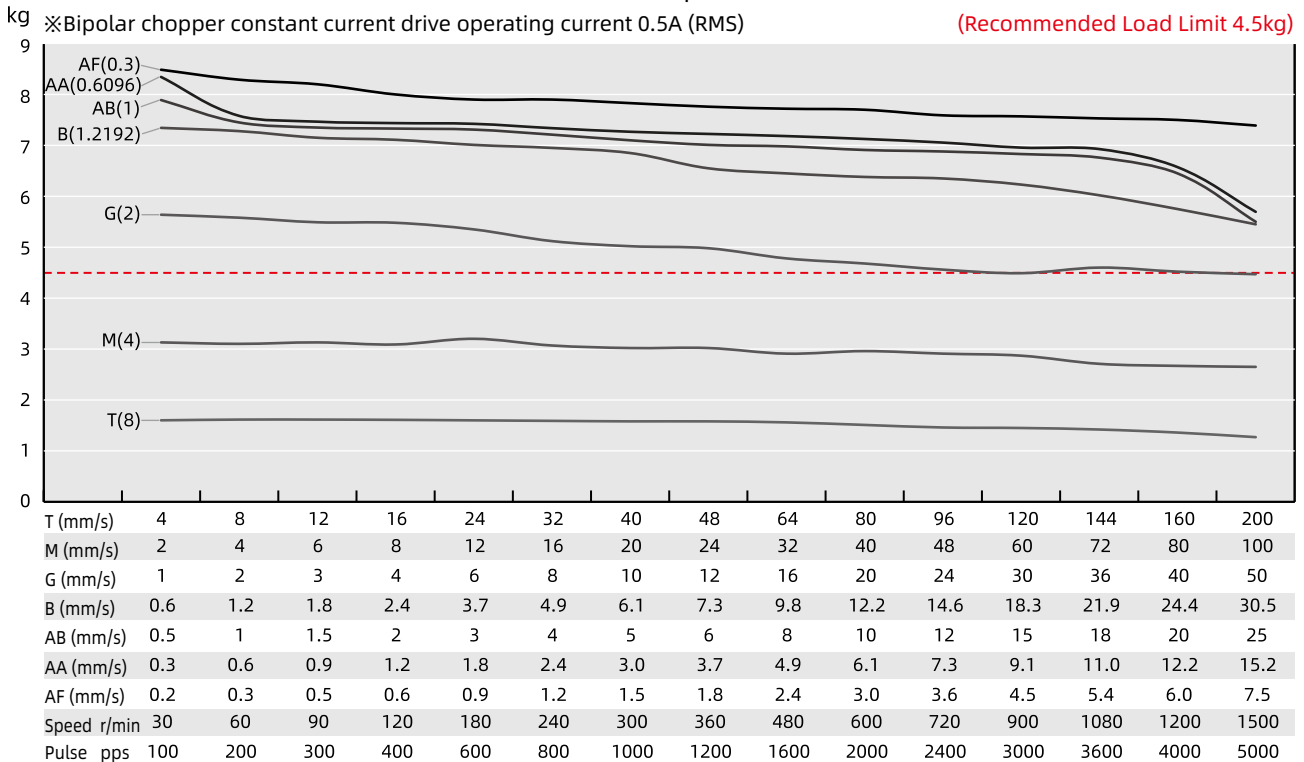

TEST CONDITION

Testing Voltage: 24Vdc, Driver Model: DS-OLS2-FPD bipolar, chopper driver at rated current (rms).
Motor's thrust will be changed with different voltage and driver. 50% thrust margin is recommended.

Size 11 (28mm) Series

Size 11 [28mm] Stepper Lead Screw Linear Actuator occupies a mounting footprint of slightly above 1 in² and provides over 140N of continuous thrust, over 3x as that of the size 8.



Motor Characteristics

| Motor | Voltage (V) | Current (A _{RMS}) | Resistance (Ω) | Inductance (mH) | Weight (g) | Lead Wire No. | Motor Length (mm) |
|---------|-------------|-----------------------------|----------------|-----------------|------------|---------------|-------------------|
| 11-2105 | 4.55 | 0.5 | 9.1 | 6 | 117 | 4 | 33.35 |
| 11-2110 | 2.1 | 1 | 2.1 | 1.5 | 117 | 4 | 33.35 |
| 11-2209 | 3.9 | 0.95 | 4.1 | 4 | 173 | 4 | 45 |
| 11-2216 | 2.4 | 1.6 | 1.5 | 1.3 | 173 | 4 | 45 |

Note : Motor Insulation Class B, Motor Temperature Rise 80°C, Ambient Temperature -20°C~55°C

Available Lead Screw and Travel per Step

| Screw Dia. (inch) | Screw Dia. (mm) | Lead (inch) | Lead (mm) | Lead Code | Travel Per Step @1.8° (mm)* |
|-------------------|-----------------|-------------|-----------|-----------|-----------------------------|
| 0.188 | 4.77 | 0.0125 | 0.3175 | AL | 0.0016 |
| 0.188 | 4.77 | 0.025 | 0.635 | A | 0.0032 |
| 0.188 | 4.77 | 0.05 | 1.27 | D | 0.0063 |
| 0.218 | 5.56 | 0.096 | 2.4384 | J* | 0.0122 |
| 0.188 | 4.77 | 0.1 | 2.54 | K | 0.0127 |
| 0.218 | 5.56 | 0.192 | 4.8768 | Q* | 0.0244 |
| 0.188 | 4.77 | 0.2 | 5.08 | R | 0.0254 |
| 0.188 | 4.77 | 0.4 | 10.16 | X | 0.0508 |

* Motor wiring and screw lead could be customized according to customer's request

* Value Truncated

* 5.56mm diameter screw only can be applied in External Type

Size 11 (28mm) Series

Dimensional Drawings : External Actuator

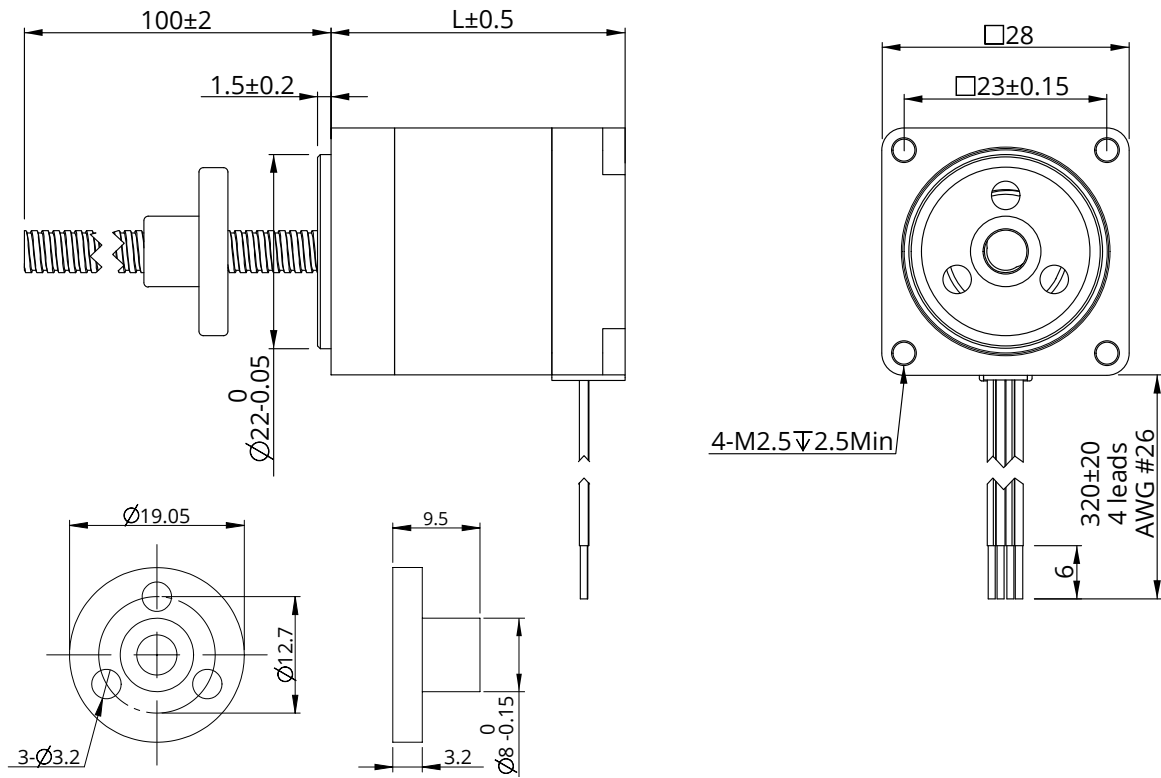

Dimensional Drawings : Non-Captive Actuator

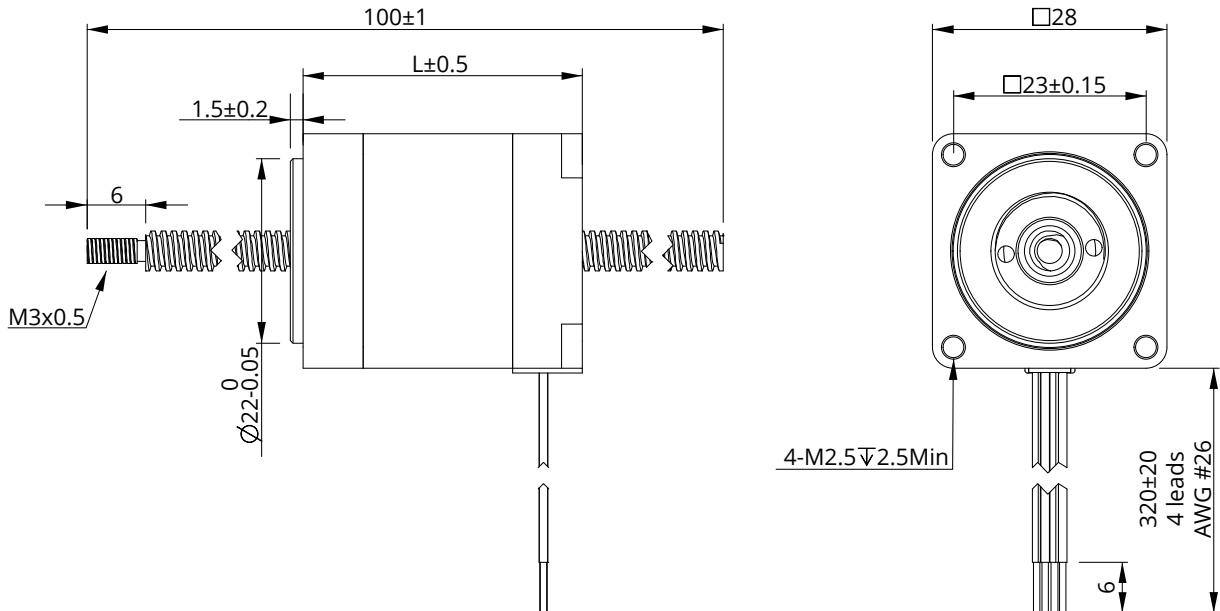

Size 11 (28mm) Series

Dimensional Drawings : Electric Cylinder (Captive) Actuator

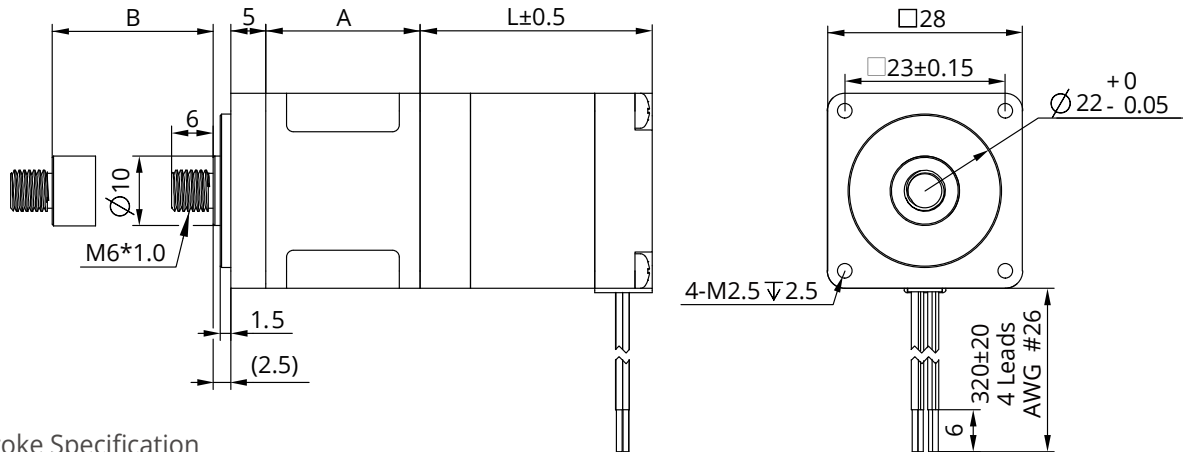

Stroke Specification

| Size A (mm) | Stroke B (mm) | Size L (mm) | |
|-------------|---------------|-------------------------------|----------------------------|
| 22.2 | 12.7 | Single stack motor 33.35mm | Double stack motor 45mm |
| 28.55 | 19.05 | | |
| 34.9 | 25.4 | | |
| 41.3 | 31.8 | | |
| 47.6 | 38.1 | | |
| 60.3 | 50.8 | | |
| 73 | 63.5 | | |

Dimensional Drawings : Kaptive Actuator

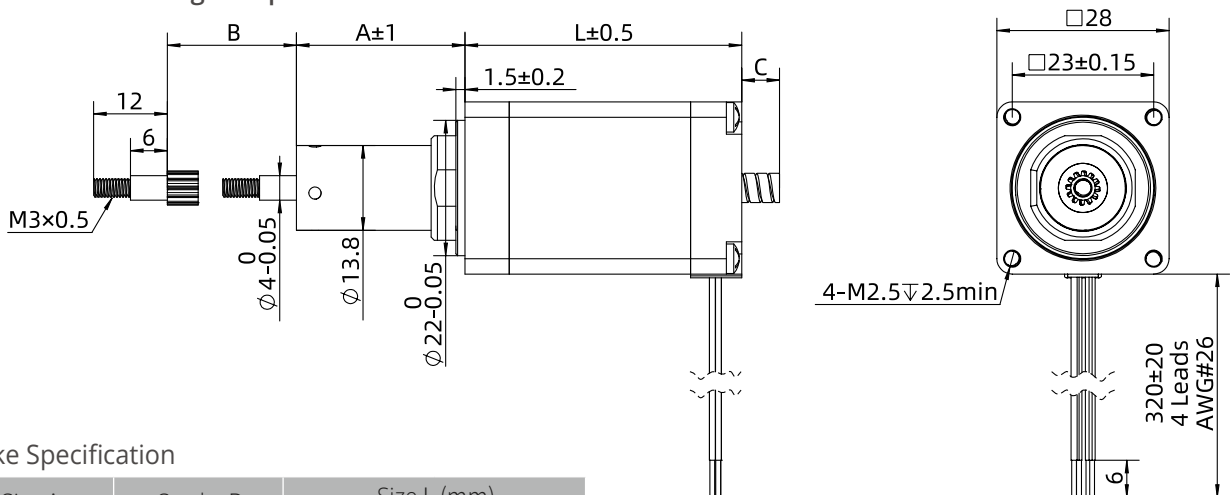

Stroke Specification

| Size A (mm) | Stroke B (mm) | Size L (mm) | |
|-------------|---------------|-------------|------|
| | | L=33.35 | L=45 |
| 14.7 | 12.7 | 1 | 0 |
| 22.1 | 19.05 | 7.8 | 0 |
| 27.4 | 25.4 | 13.7 | 4.6 |
| 33.8 | 31.8 | 20.1 | 11 |
| 40.1 | 38.1 | 26.4 | 17.4 |
| 52.8 | 50.8 | 39 | 29.8 |
| 65.5 | 63.5 | 52.7 | 42.5 |

For stroke customization, please contact DINGS' or local representative.

Size 11 (28mm) Series

Speed Thrust Curves

Size 11 Single Stack Speed Thrust Curves

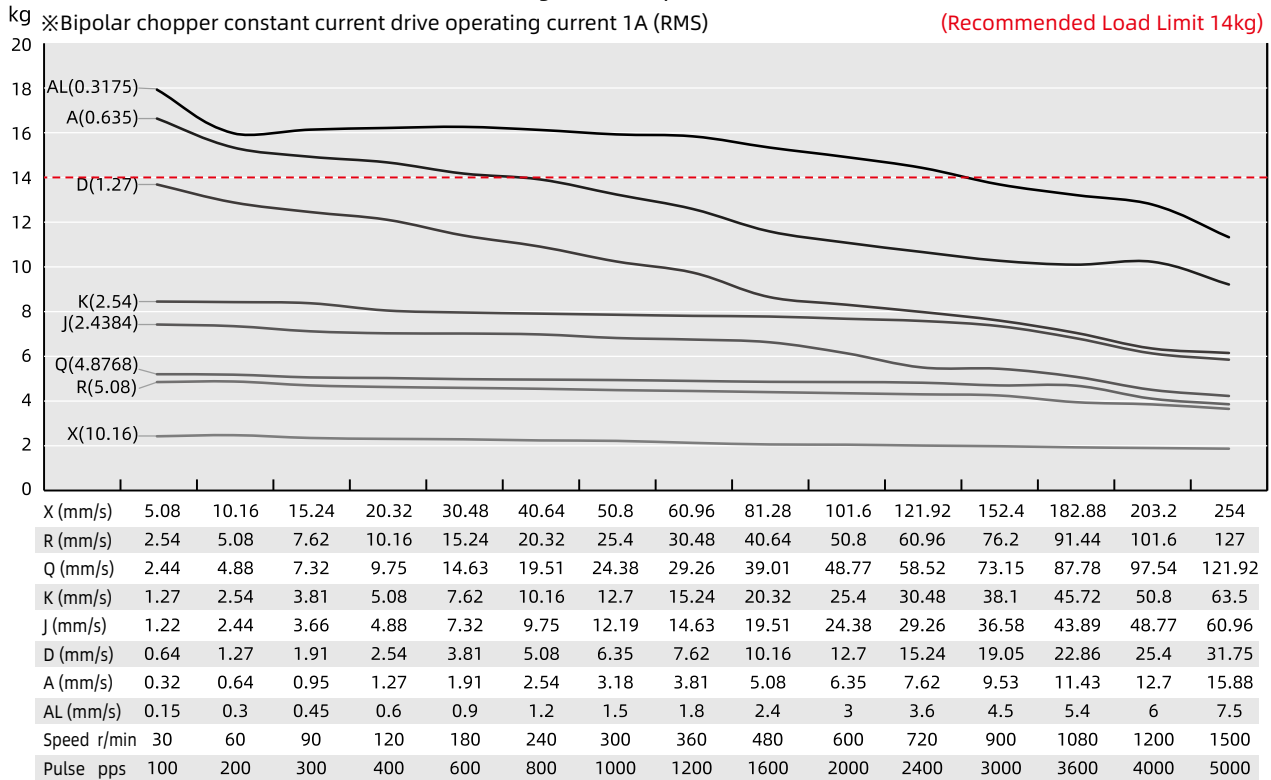

Size 11 Double Stack Speed Thrust Curves

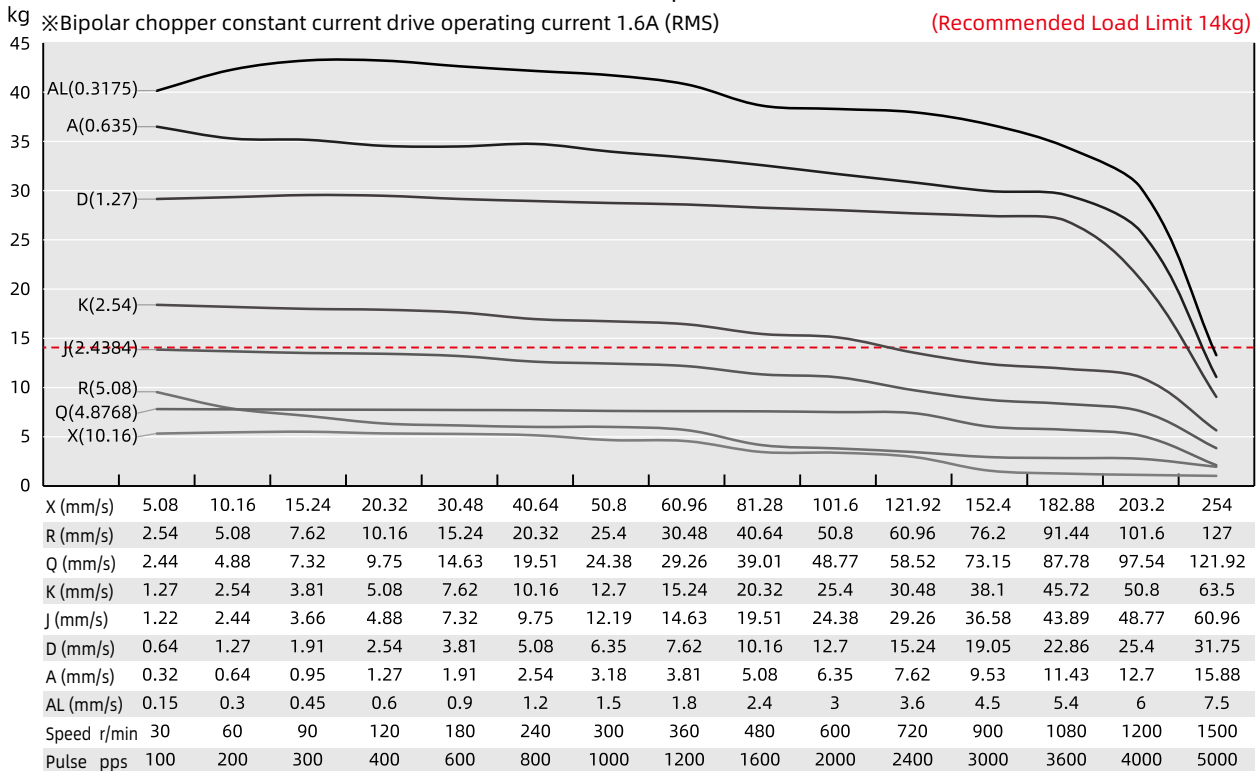

TEST CONDITION

Testing Voltage: 24Vdc, Driver Model: DS-OLS2-FPD bipolar, chopper driver at rated current (rms).
Motor's thrust will be changed with different voltage and driver. 50% thrust margin is recommended.

Size 14 (35mm) Series

Size 14 [35mm] Stepper Lead Screw Linear Actuator is widely used for linear movement applications, providing up to 230N of continuous thrust.



Motor Characteristics

| Motor | Voltage (V) | Current (A _{RMS}) | Resistance (Ω) | Inductance (mH) | Weight (g) | Lead Wire No. | Motor Length (mm) |
|---------|-------------|-----------------------------|----------------|-----------------|------------|---------------|-------------------|
| 14-2105 | 6.6 | 0.5 | 13.2 | 14 | 189 | 4 | 33.6 |
| 14-2110 | 3.5 | 1 | 3.5 | 3.6 | 189 | 4 | 33.6 |
| 14-2115 | 2.7 | 1.5 | 1.8 | 1.9 | 189 | 4 | 33.6 |
| 14-2205 | 12 | 0.5 | 24 | 29 | 210 | 4 | 45.6 |
| 14-2210 | 6 | 1 | 6 | 7.2 | 210 | 4 | 45.6 |
| 14-2215 | 4 | 1.5 | 2.7 | 3.2 | 210 | 4 | 45.6 |

Note : Motor Insulation Class B, Motor Temperature Rise 80°C, Ambient Temperature -20°C~55°C

Available Lead Screw and Travel per Step

| Screw Dia. (inch) | Screw Dia. (mm) | Lead (inch) | Lead (mm) | Lead Code | Travel Per Step @1.8° (mm)* | Travel Per Step @0.9° (mm)* |
|-------------------|-----------------|-------------|-----------|-----------|-----------------------------|-----------------------------|
| 0.25 | 6.35 | 0.024 | 0.6096 | AA | 0.003 | 0.0015 |
| 0.236/0.25/0.315 | 6/6.35/8 | 0.0394 | 1 | AB | 0.005 | 0.0025 |
| 0.25 | 6.35 | 0.025 | 0.635 | A | 0.003175 | 0.0015 |
| 0.25 | 6.35 | 0.048 | 1.2192 | B | 0.006 | 0.003 |
| 0.25 | 6.35 | 0.05 | 1.27 | D | 0.0064 | 0.0032 |
| 0.25 | 6.35 | 0.0625 | 1.5875 | F | 0.0079 | 0.004 |
| 0.25 | 6.35 | 0.096 | 2.4384 | J | 0.0122 | 0.0061 |
| 0.25 | 6.35 | 0.1 | 2.54 | K* | 0.0127 | 0.0064 |
| 0.25 | 6.35 | 0.125 | 3.175 | L* | 0.0159 | 0.0079 |
| 0.25 | 6.35 | 0.192 | 4.8768 | Q | 0.024 | 0.0122 |
| 0.25 | 6.35 | 0.2 | 5.08 | R* | 0.0254 | 0.0127 |
| 0.25 | 6.35 | 0.25 | 6.35 | S* | 0.0318 | 0.0159 |
| 0.25 | 6.35 | 0.3333 | 8.4667 | U | 0.0423 | 0.0212 |
| 0.25 | 6.35 | 0.384 | 9.7536 | W* | 0.0488 | 0.0244 |
| 0.25 | 6.35 | 0.5 | 12.7 | Y* | 0.0635 | 0.0318 |
| 0.25 | 6.35 | 1 | 25.4 | Z* | 0.127 | 0.0635 |
| 0.25 | 6.35 | 0.0313 | 0.794 | N | 0.00397 | 0.002 |
| 0.315 | 8 | 0.1575 | 4 | M | 0.02 | 0.01 |
| 0.315 | 8 | 0.315 | 8 | T | 0.04 | 0.02 |
| 0.25/0.315 | 6.35/8 | 0.0787 | 2 | G | 0.01 | 0.005 |
| 0.236/0.315 | 6/8 | 0.1969 | 5 | E | 0.025 | 0.0125 |
| 0.315 | 8 | 0.3937 | 10 | C | 0.05 | 0.025 |

* Motor wiring and screw lead could be customized according to customer's request

* Value Truncated

* 9.525mm diameter screw only can be applied in External Type

Size 14 (35mm) Series

Dimensional Drawings : External Actuator

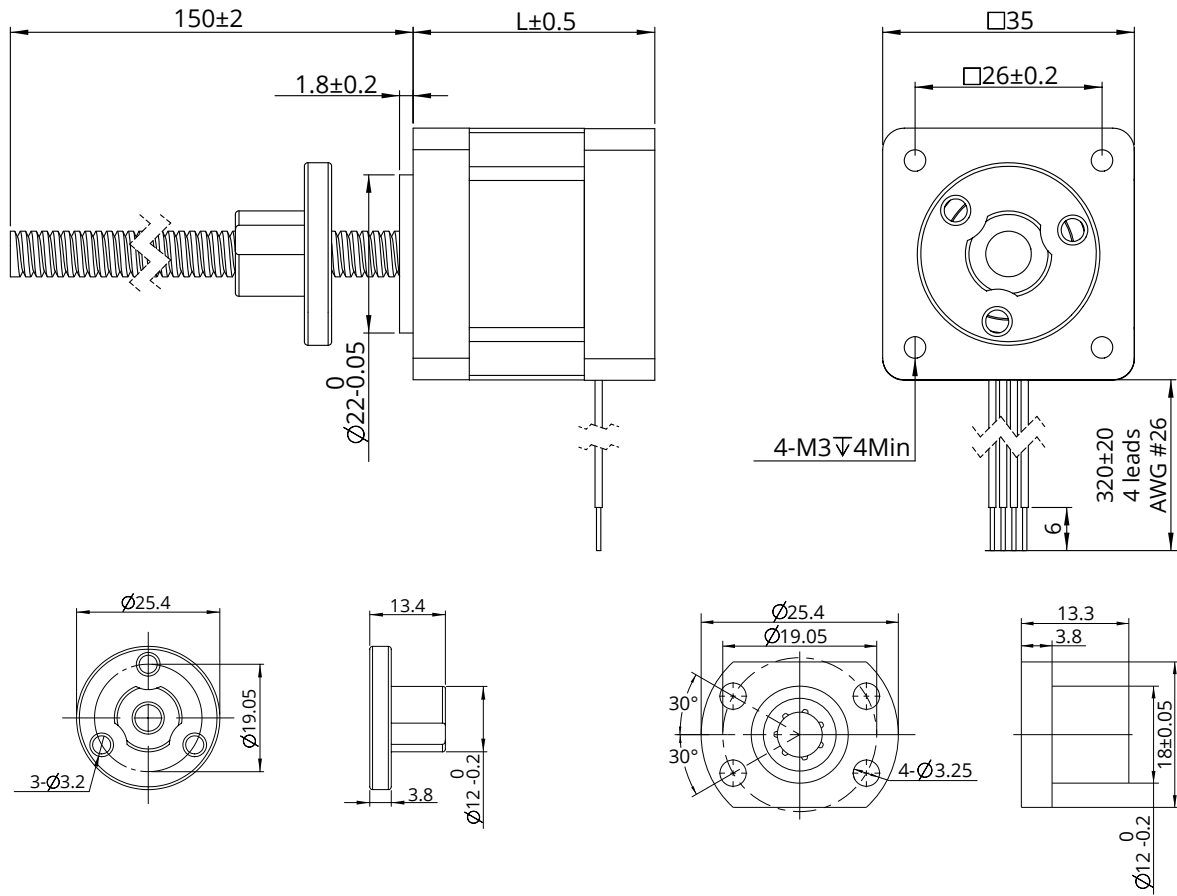

Dimensional Drawings : Non-Captive Actuator

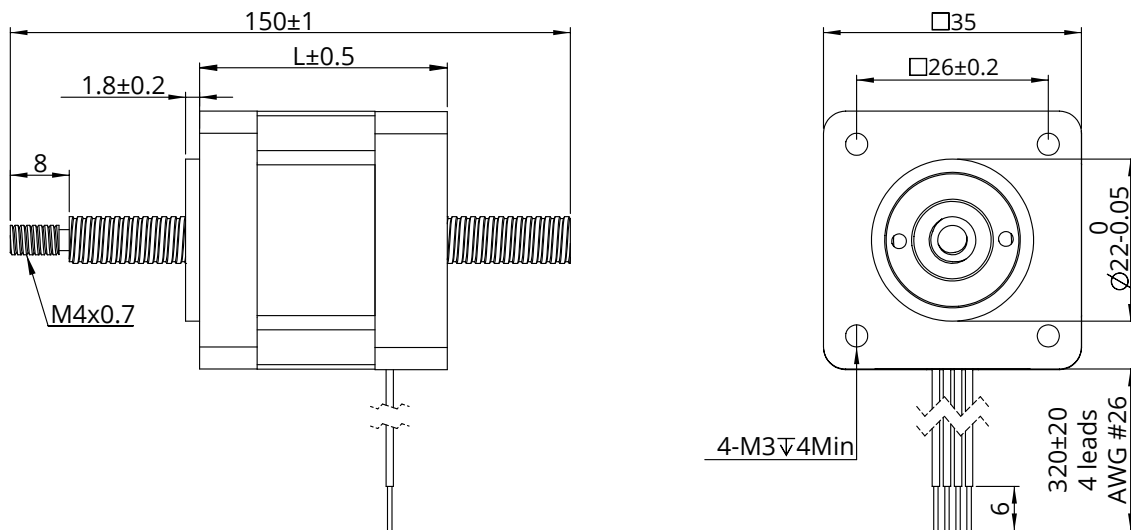

Note : All drawings are 1st Angle Projection - ISO Compliant (3D models available)

Size 14 (35mm) Series

Dimensional Drawings : Electric Cylinder (Captive) Actuator

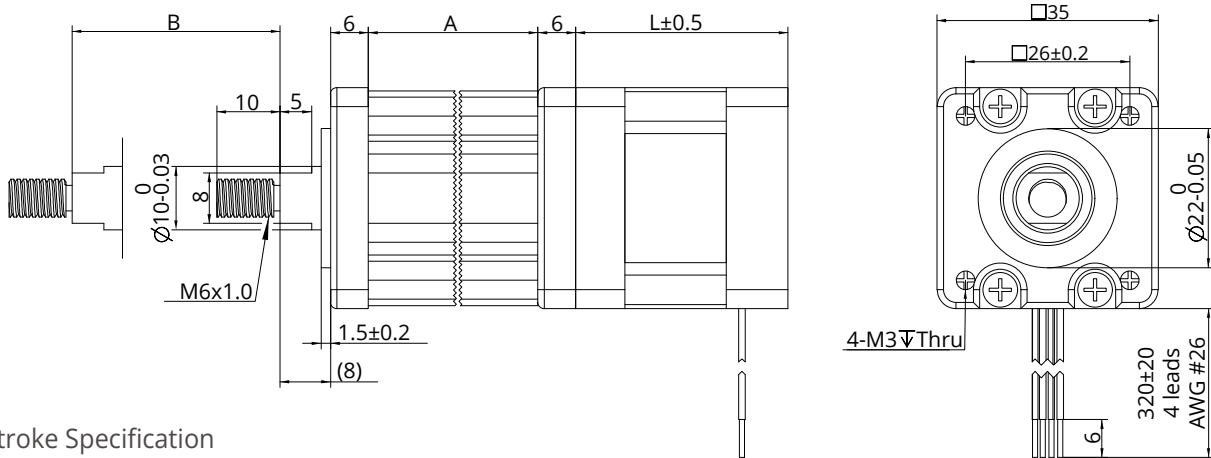

Stroke Specification

| Size A (mm) | Stroke B (mm) | Size L (mm) | |
|-------------|---------------|------------------------------|------------------------------|
| 35.7 | 12.7 | Single stack motor 33.6mm | Double stack motor 45.6mm |
| 42.05 | 19.05 | | |
| 48.4 | 25.4 | | |
| 54.8 | 31.8 | | |
| 61.1 | 38.1 | | |
| 73.8 | 50.8 | | |
| 86.5 | 63.5 | | |

Dimensional Drawings : Kaptive Actuator

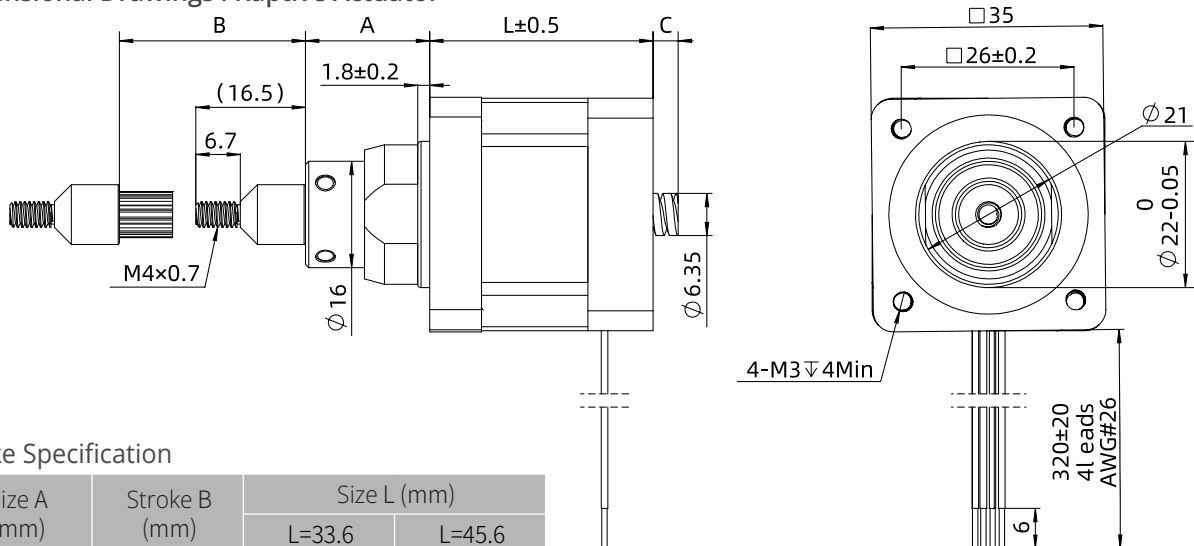

Stroke Specification

| Size A (mm) | Stroke B (mm) | Size L (mm) | |
|-------------|---------------|-------------|--------|
| | | L=33.6 | L=45.6 |
| 18.7 | 12.7 | 3.8 | 0.8 |
| 25.05 | 19.05 | 10.15 | 7.15 |
| 31.4 | 25.4 | 16.5 | 13.5 |
| 37.75 | 31.75 | 22.85 | 19.85 |
| 44.1 | 38.1 | 29.2 | 26.2 |
| 56.8 | 50.8 | 41.9 | 38.9 |
| 69.5 | 63.5 | 54.6 | 51.6 |

For stroke customization, please contact DINGS' or local representative.

Size 14 (35mm) Series

Speed Thrust Curves

Size 14 Single Stack Speed Thrust Curves

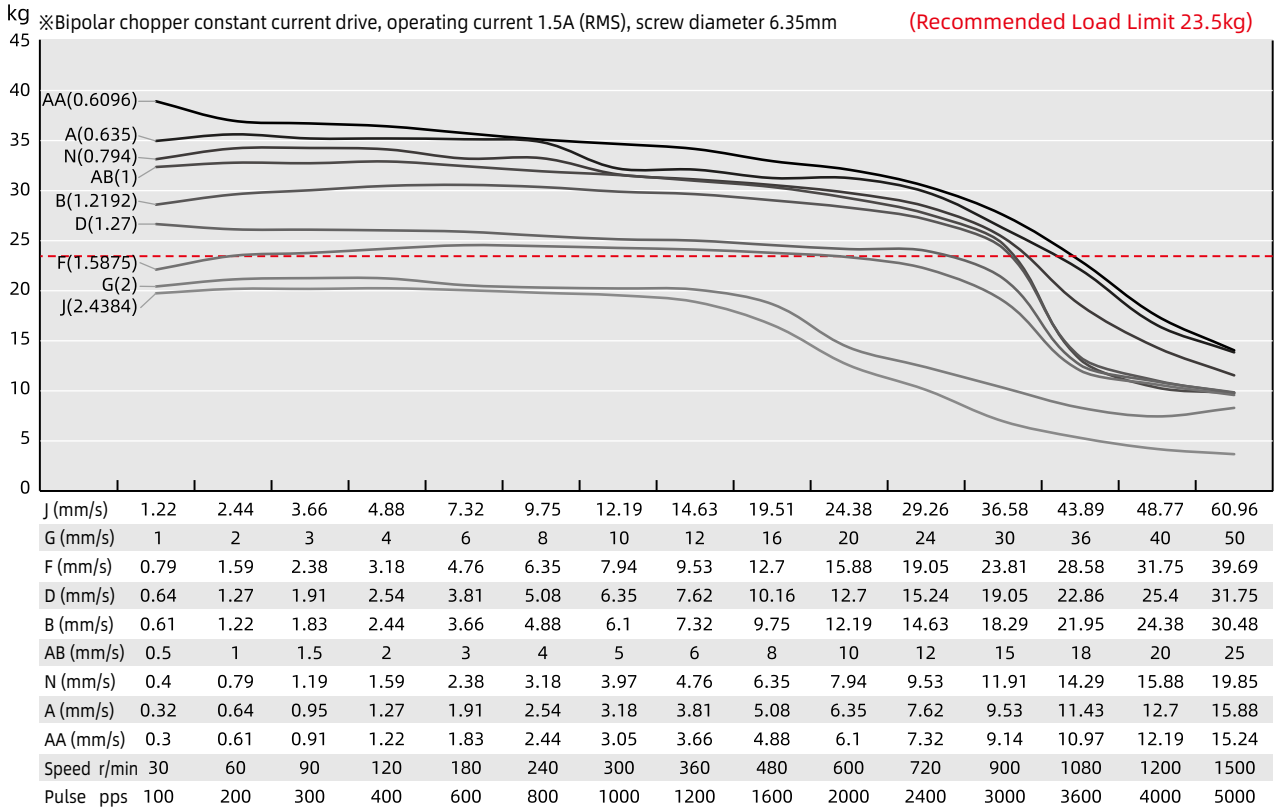

Size 14 Single Stack Speed Thrust Curves

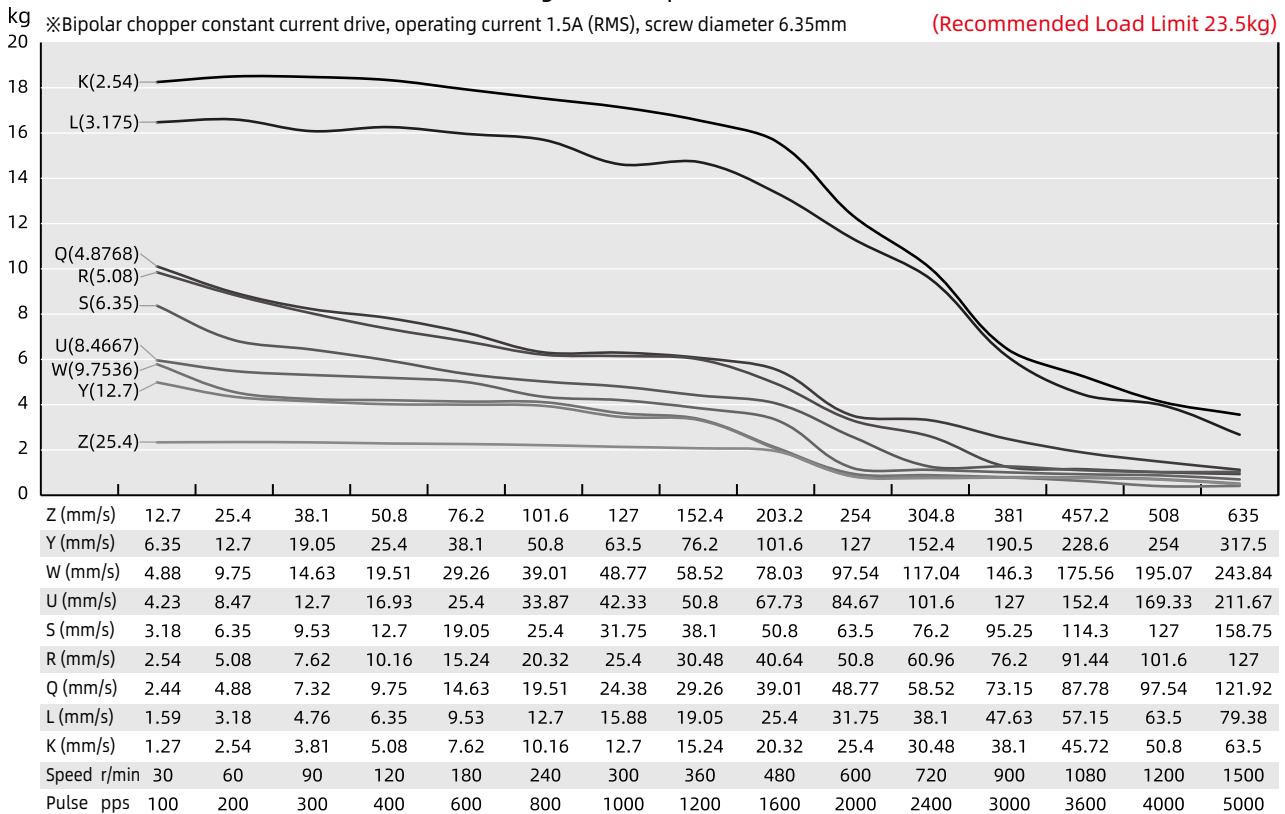

TEST CONDITION

Testing Voltage: 24Vdc, Driver Model: DS-OLS2-FPD bipolar, chopper driver at rated current (rms).

Motor's thrust will be changed with different voltage and driver. 50% thrust margin is recommended.

Size 14 (35mm) Series

Size 14 Single Stack Speed Thrust Curves

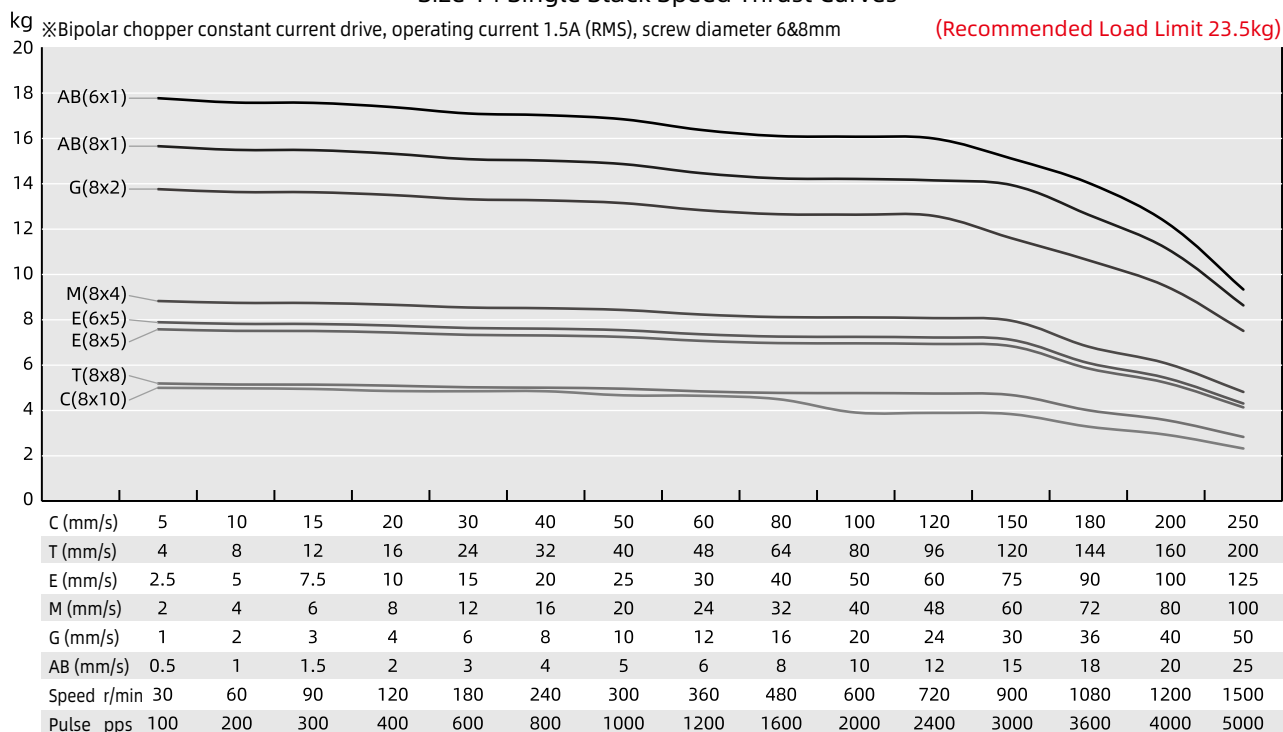

Size 14 Double Stack Speed Thrust Curves

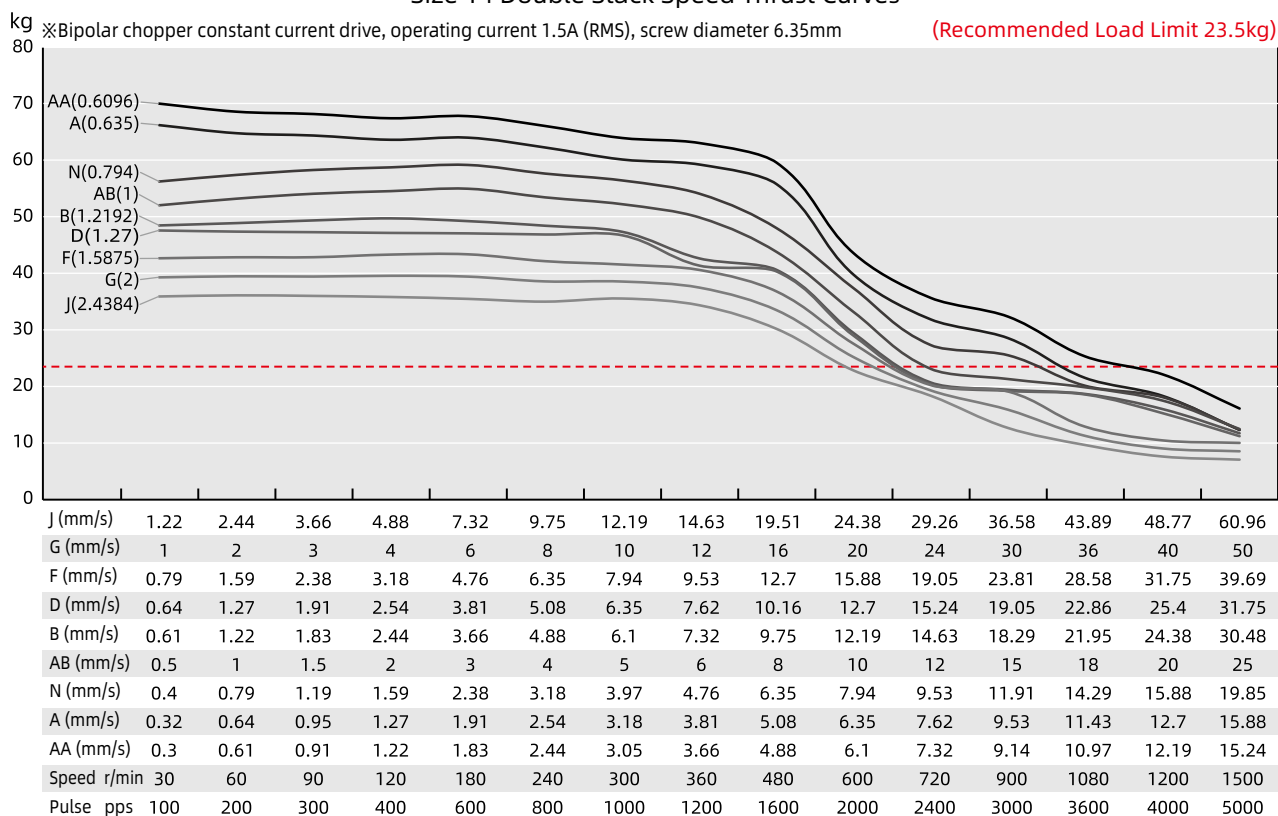

TEST CONDITION

Testing Voltage: 24Vdc, Driver Model: DS-OLS2-FPD bipolar, chopper driver at rated current (rms).
Motor's thrust will be changed with different voltage and driver. 50% thrust margin is recommended.

Size 14 (35mm) Series

Size 14 Double Stack Speed Thrust Curves

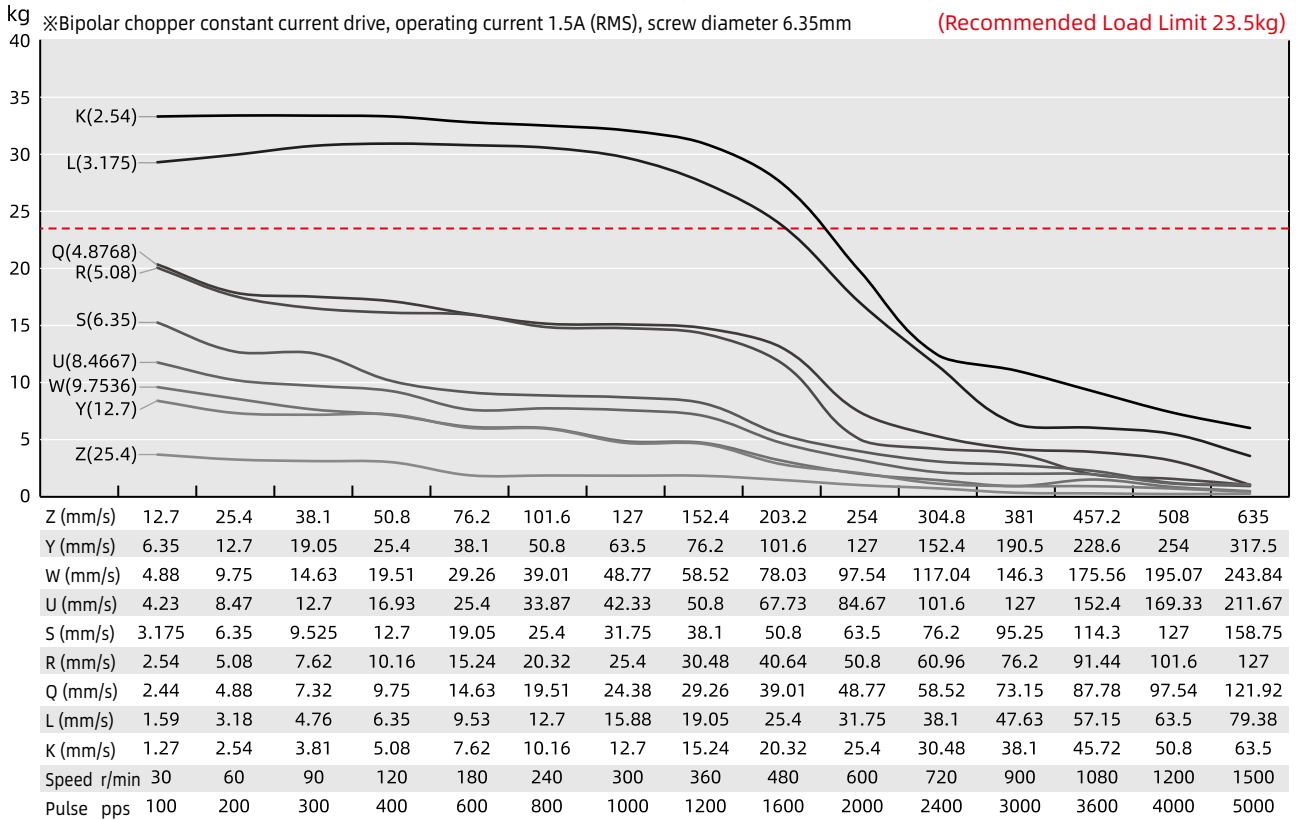

Size 14 Double Stack Speed Thrust Curves

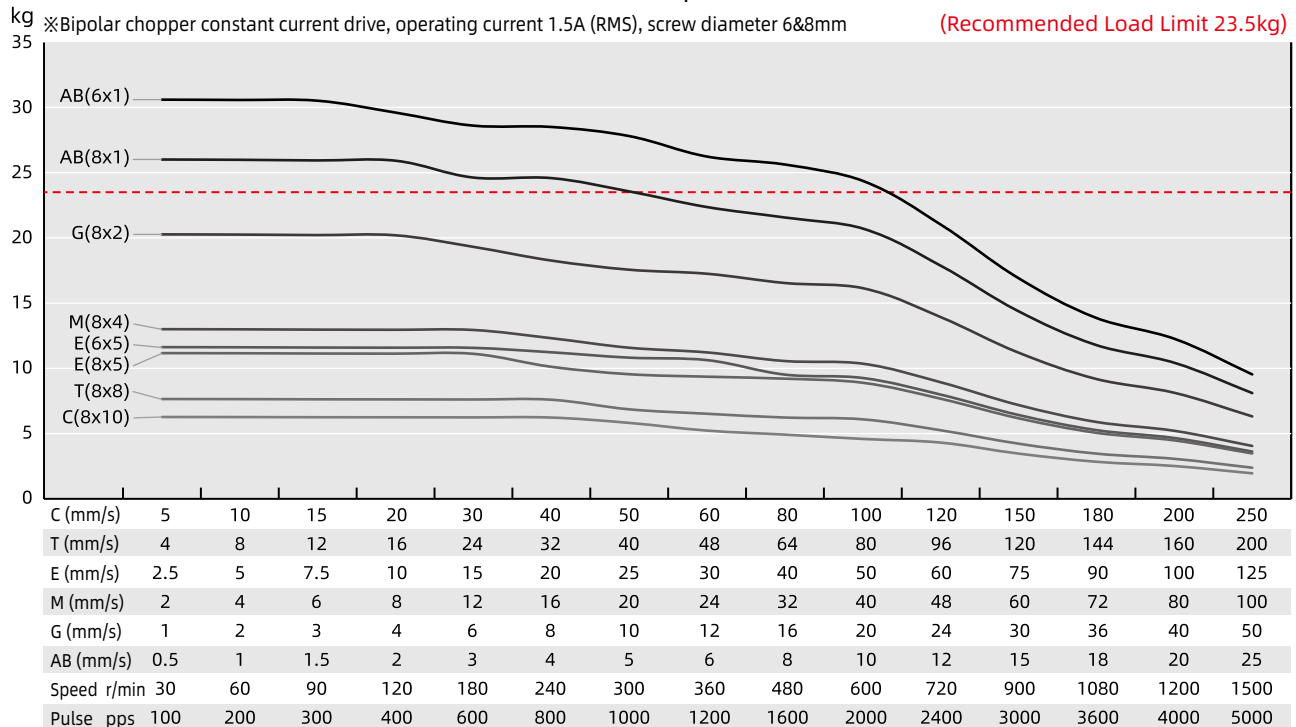

TEST CONDITION

Testing Voltage: 24Vdc, Driver Model: DS-OLS2-FPD bipolar, chopper driver at rated current (rms).
Motor's thrust will be changed with different voltage and driver. 50% thrust margin is recommended.

Size 17 (42mm) Series

Size 17 [42mm] Stepper Lead Screw Linear Actuator is widely used for linear movement applications, providing up to 330N of continuous thrust.



Motor Characteristics

| Motor | Voltage (V) | Current (A _{RMS}) | Resistance (Ω) | Inductance (mH) | Weight (g) | Lead Wire No. | Motor Length (mm) |
|---------|-------------|-----------------------------|----------------|-----------------|------------|---------------|-------------------|
| 17-2105 | 7.2 | 0.5 | 14.4 | 19.8 | 254 | 4 | 34.1 |
| 17-2110 | 3.8 | 1 | 3.8 | 5 | 254 | 4 | 34.1 |
| 17-2115 | 2.85 | 1.5 | 1.9 | 2.2 | 254 | 4 | 34.1 |
| 17-2205 | 11 | 0.5 | 22 | 46 | 386 | 4 | 48.1 |
| 17-2212 | 4.5 | 1.2 | 3.8 | 8 | 386 | 4 | 48.1 |
| 17-2225 | 2.5 | 2.5 | 1 | 1.8 | 386 | 4 | 48.1 |

Note : Motor Insulation Class B, Motor Temperature Rise 80°C, Ambient Temperature -20°C~55°C

Available Lead Screw and Travel per Step

| Screw Dia. (inch) | Screw Dia. (mm) | Lead (inch) | Lead (mm) | Lead Code | Travel Per Step @1.8° (mm)* | Travel Per Step @0.9° (mm)* |
|-------------------|-----------------|-------------|-----------|-----------|-----------------------------|-----------------------------|
| 0.25 | 6.35 | 0.024 | 0.6096 | AA | 0.003 | 0.0015 |
| 0.236/0.25/0.315 | 6/6.35/8 | 0.0394 | 1 | AB | 0.005 | 0.0025 |
| 0.25 | 6.35 | 0.025 | 0.635 | A | 0.003175 | 0.0015 |
| 0.25 | 6.35 | 0.048 | 1.2192 | B | 0.006 | 0.003 |
| 0.25 | 6.35 | 0.05 | 1.27 | D | 0.0064 | 0.0032 |
| 0.25 | 6.35 | 0.0625 | 1.5875 | F | 0.0079 | 0.004 |
| 0.25 | 6.35 | 0.096 | 2.4384 | J | 0.0122 | 0.0061 |
| 0.25 | 6.35 | 0.1 | 2.54 | K* | 0.0127 | 0.0064 |
| 0.25 | 6.35 | 0.125 | 3.175 | L* | 0.0159 | 0.0079 |
| 0.25 | 6.35 | 0.192 | 4.8768 | Q | 0.024 | 0.0122 |
| 0.25 | 6.35 | 0.2 | 5.08 | R* | 0.0254 | 0.0127 |
| 0.25 | 6.35 | 0.25 | 6.35 | S* | 0.0318 | 0.0159 |
| 0.25 | 6.35 | 0.3333 | 8.4667 | U | 0.0423 | 0.0212 |
| 0.25 | 6.35 | 0.384 | 9.7536 | W* | 0.0488 | 0.0244 |
| 0.25 | 6.35 | 0.5 | 12.7 | Y* | 0.0635 | 0.0318 |
| 0.25 | 6.35 | 1 | 25.4 | Z* | 0.127 | 0.0635 |
| 0.25 | 6.35 | 0.0313 | 0.794 | N | 0.00397 | 0.002 |
| 0.315 | 8 | 0.1575 | 4 | M | 0.02 | 0.01 |
| 0.315 | 8 | 0.315 | 8 | T | 0.04 | 0.02 |
| 0.25/0.315 | 6.35/8 | 0.0787 | 2 | G | 0.01 | 0.005 |
| 0.236/0.315 | 6/8 | 0.1969 | 5 | E | 0.025 | 0.0125 |
| 0.315 | 8 | 0.3937 | 10 | C | 0.05 | 0.025 |

* Motor wiring and screw lead could be customized according to customer's request

* Value Truncated

* 9.525mm diameter screw only can be applied in External Type

Size 17 (42mm) Series

■ Dimensional Drawings : External Actuator

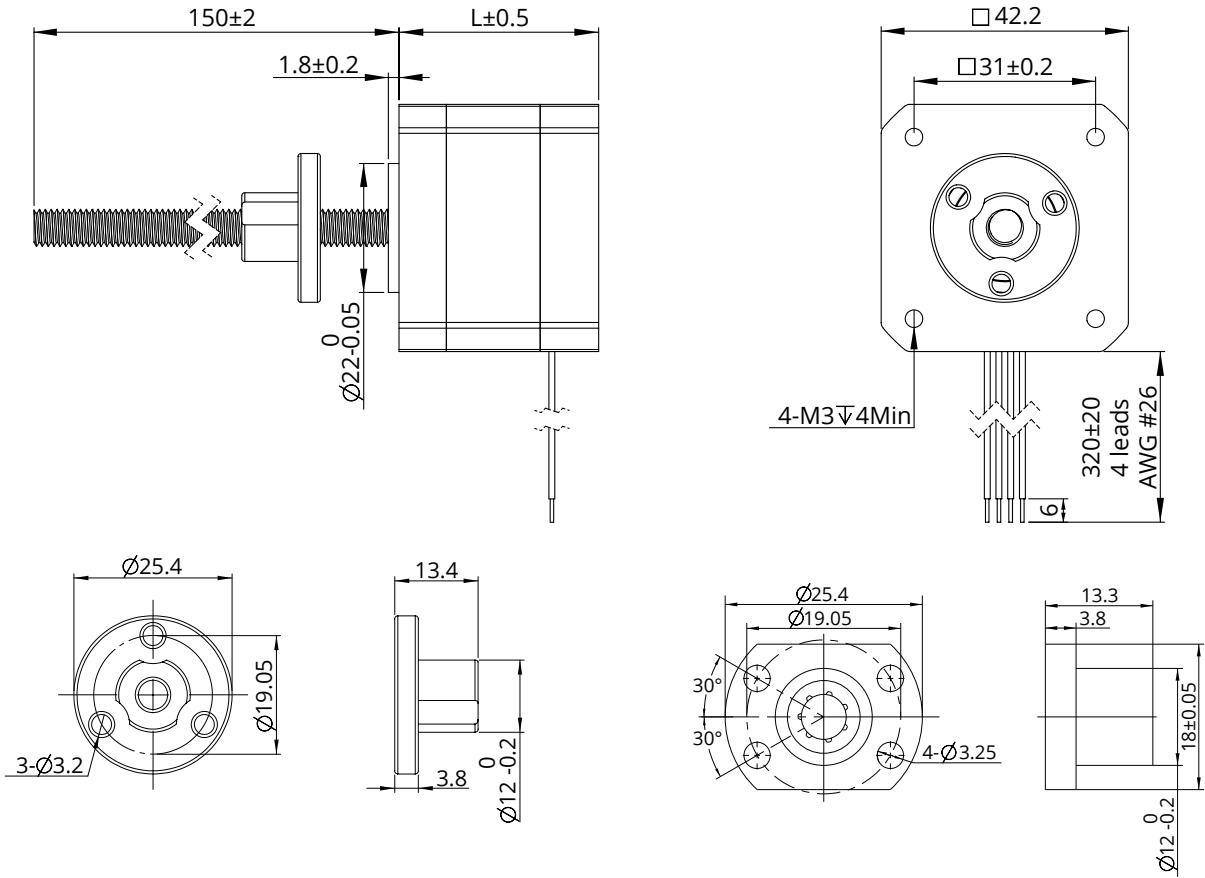

■ Dimensional Drawings : Non-Captive Actuator

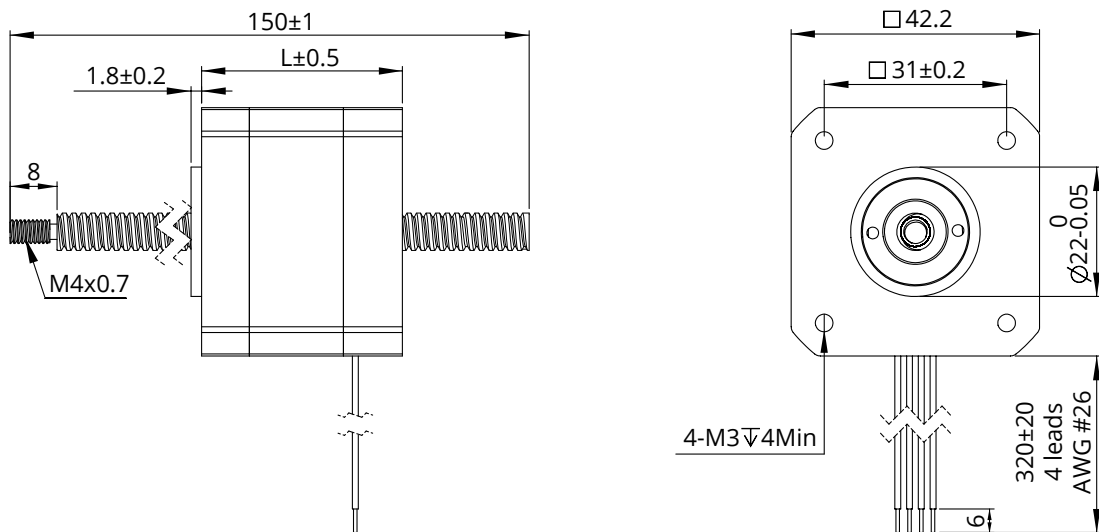

Note : All drawings are 1st Angle Projection - ISO Compliant (3D models available)

Size 17 (42mm) Series

Dimensional Drawings : Electric Cylinder (Captive) Actuator

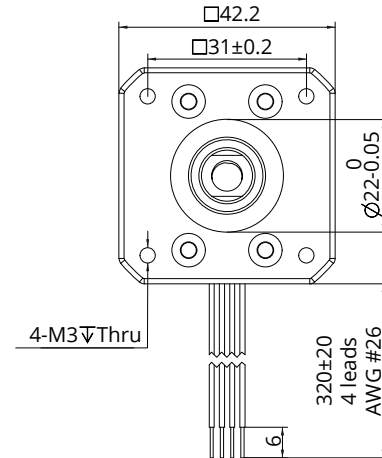
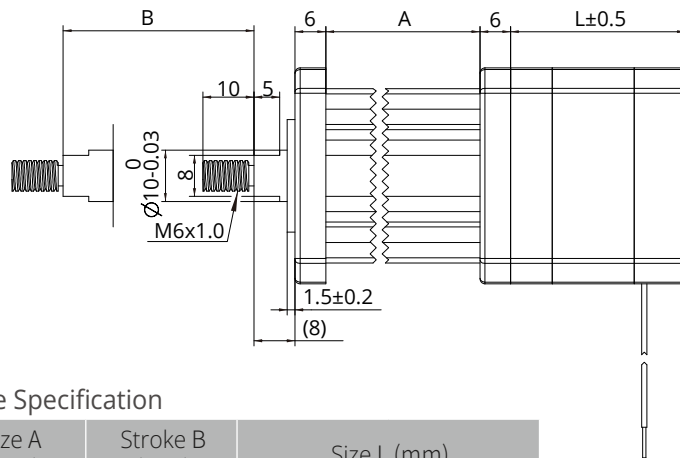

Stroke Specification

| Size A (mm) | Stroke B (mm) | Size L (mm) | |
|-------------|---------------|------------------------------|------------------------------|
| 35.7 | 12.7 | Single stack motor 34.1mm | Double stack motor 48.1mm |
| 42.05 | 19.05 | | |
| 48.4 | 25.4 | | |
| 54.8 | 31.8 | | |
| 61.1 | 38.1 | | |
| 73.8 | 50.8 | | |
| 86.5 | 63.5 | | |

Dimensional Drawings : Kaptive Actuator

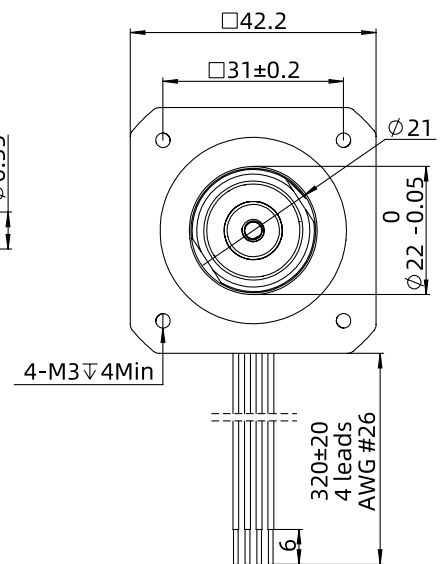
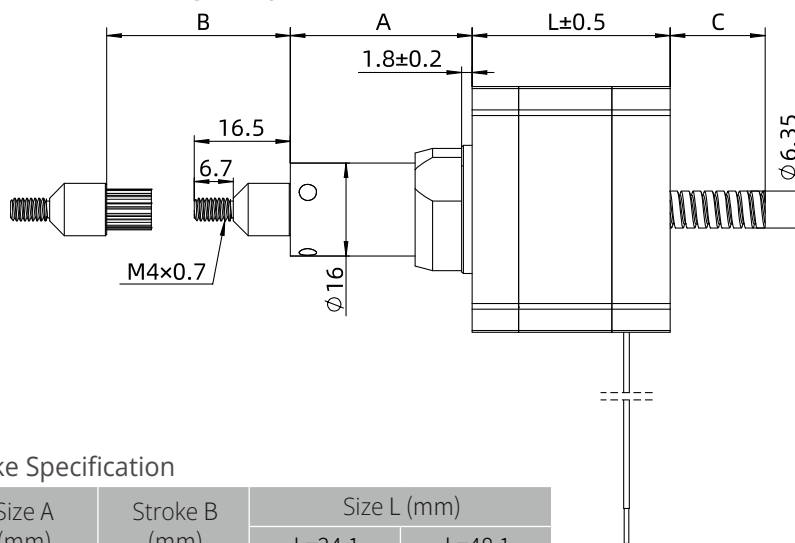

Stroke Specification

| Size A (mm) | Stroke B (mm) | Size L (mm) | |
|-------------|---------------|-------------|--------|
| | | L=34.1 | L=48.1 |
| 18.5 | 12.7 | 3.6 | 0 |
| 24.85 | 19.05 | 9.95 | 4.95 |
| 31.2 | 25.4 | 16.3 | 11.3 |
| 37.55 | 31.75 | 22.65 | 17.65 |
| 43.9 | 38.1 | 29 | 24 |
| 56.6 | 50.8 | 41.7 | 36.7 |
| 69.3 | 63.5 | 54.4 | 49.4 |

For stroke customization, please contact DINGS' or local representative.

Size 17 (42mm) Series

Speed Thrust Curves

Size 17 Single Stack Speed Thrust Curves

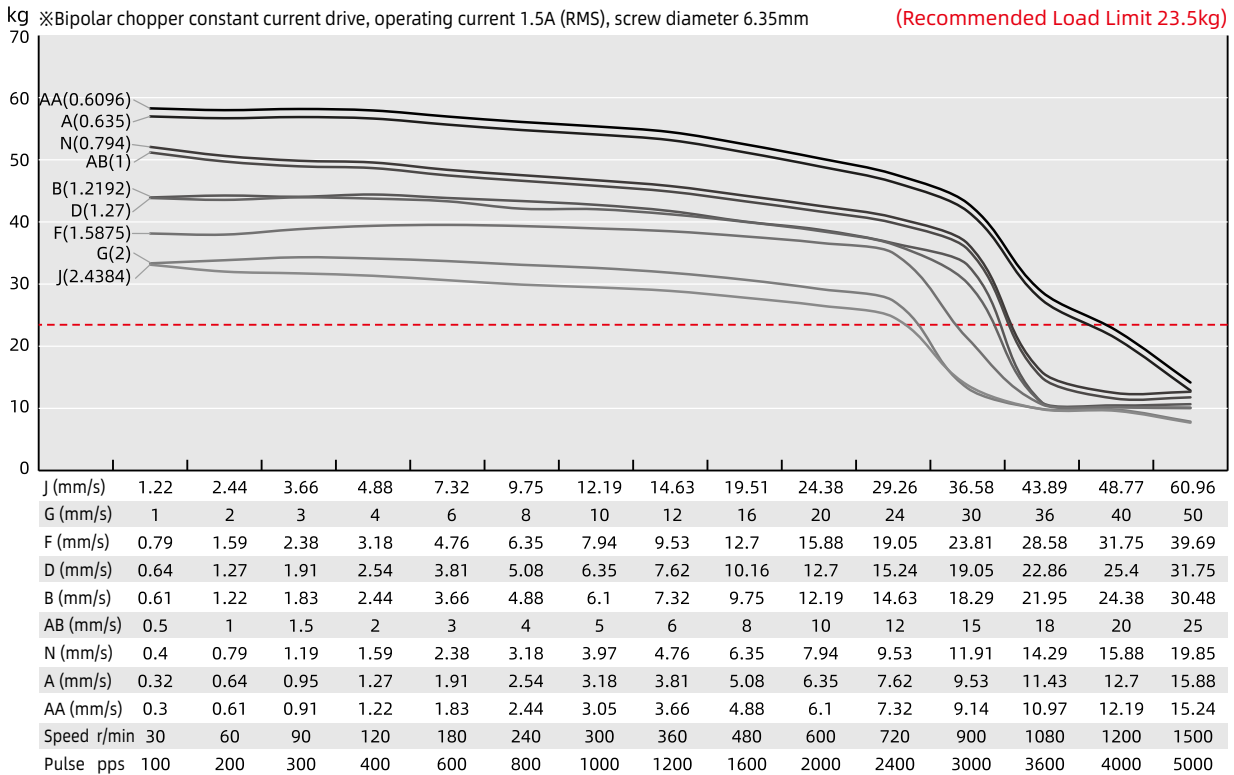

Size 17 Single Stack Speed Thrust Curves

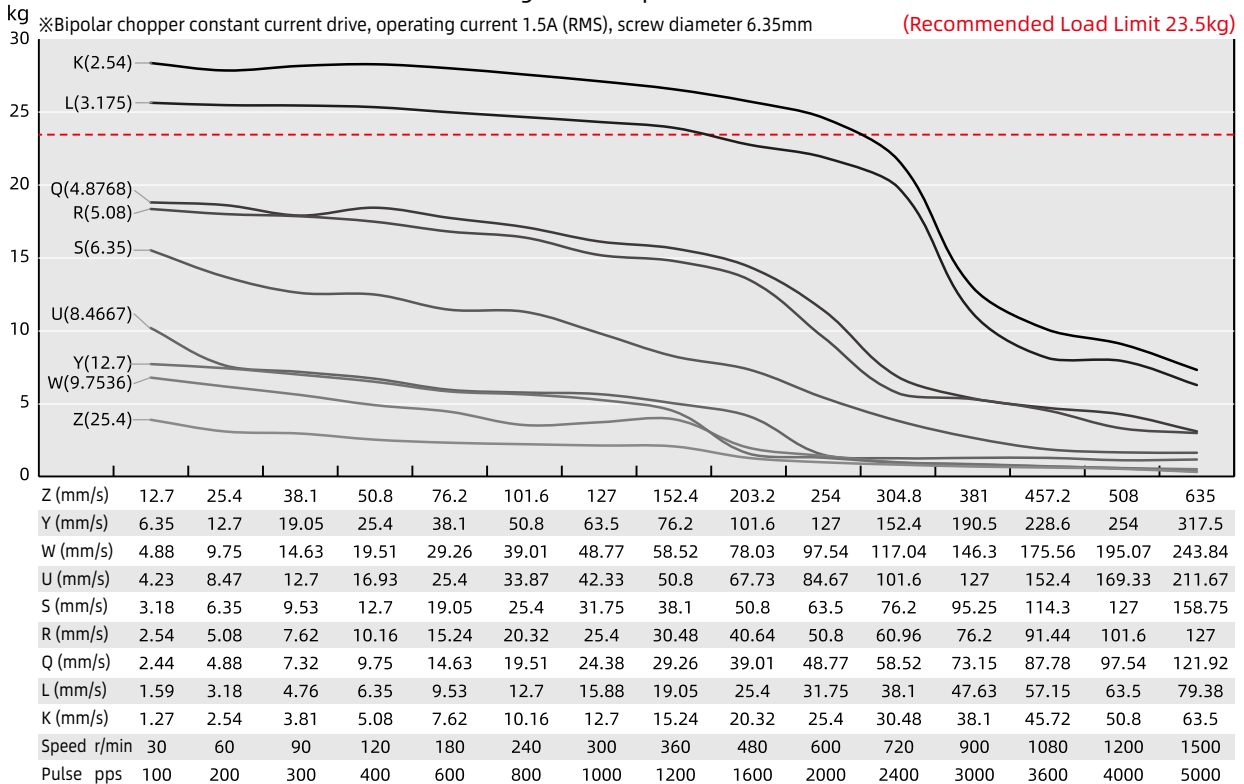

TEST CONDITION

Testing Voltage: 24Vdc, Driver Model: DS-OLS2-FPD bipolar, chopper driver at rated current (rms).
Motor's thrust will be changed with different voltage and driver. 50% thrust margin is recommended.

Size 17 (42mm) Series

Size 17 Single Stack Speed Thrust Curves

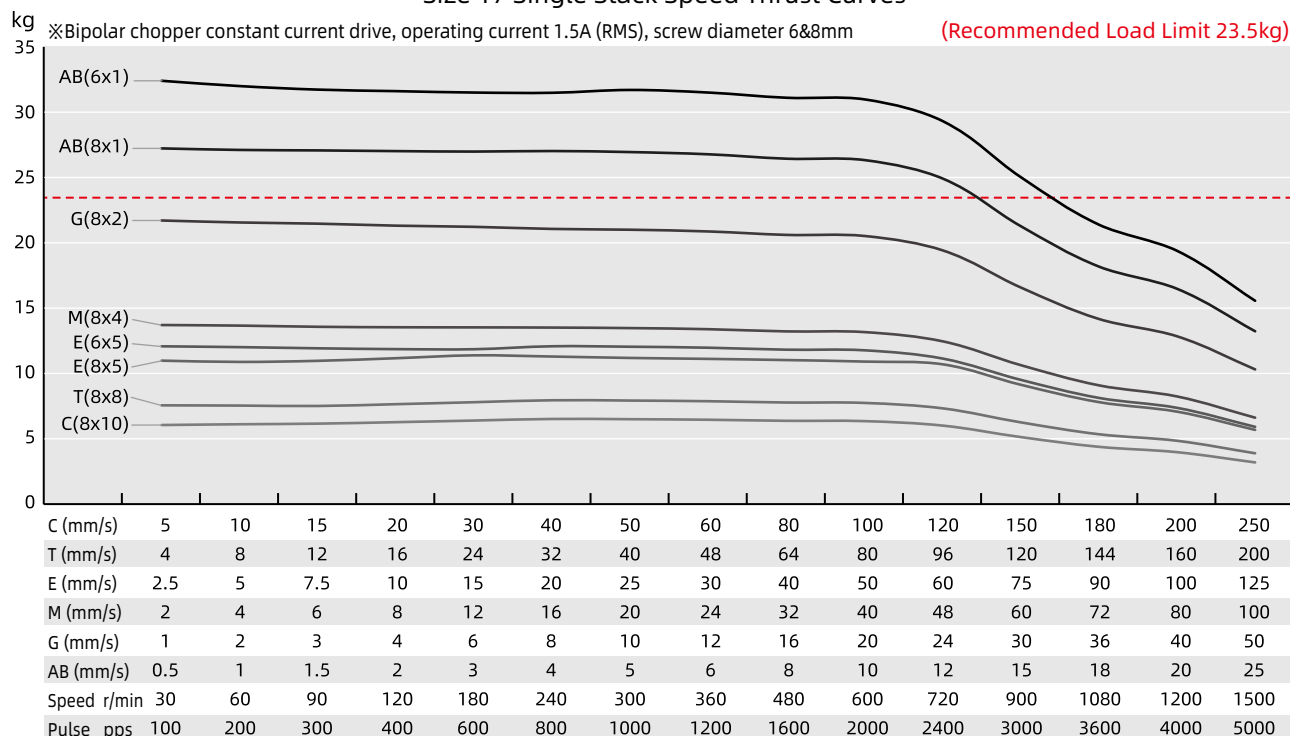

Size 17 Double Stack Speed Thrust Curves

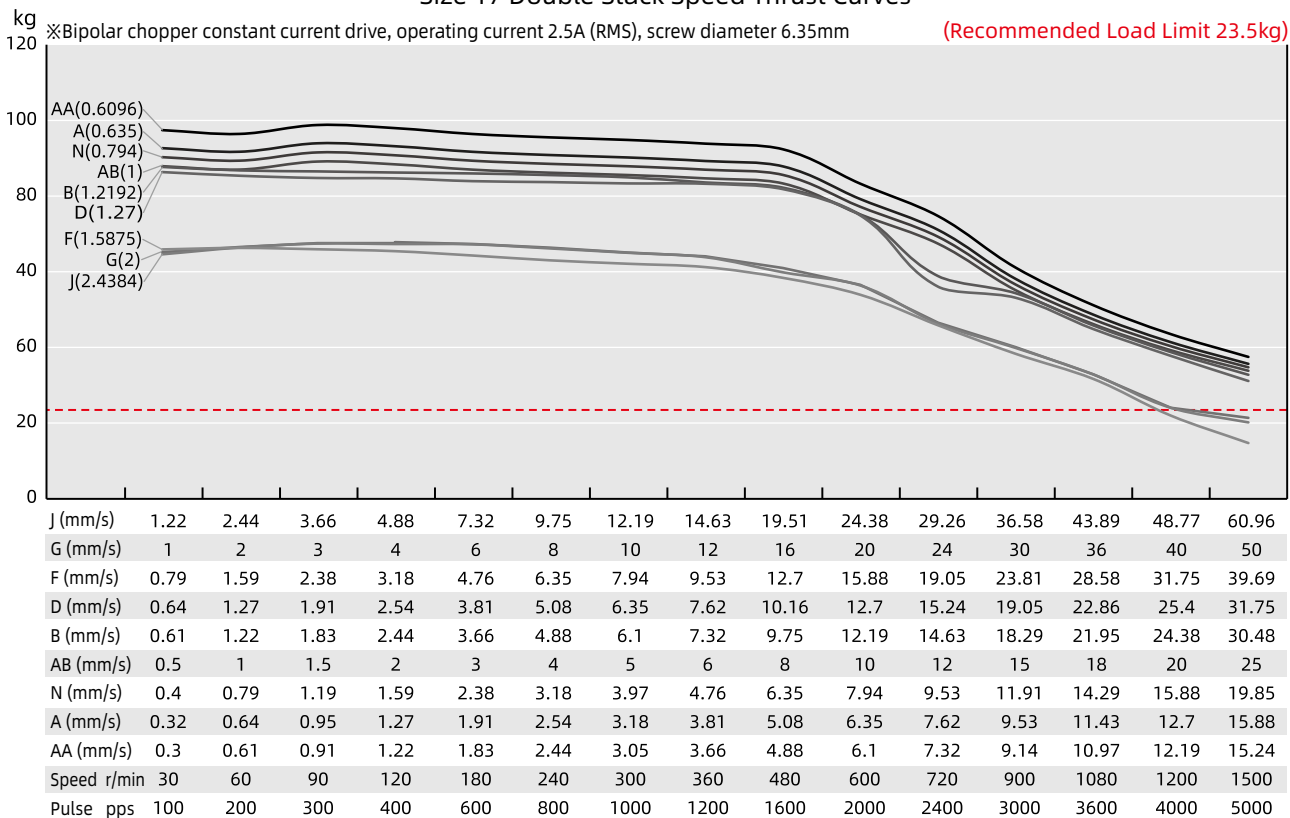

TEST CONDITION

Testing Voltage: 24Vdc, Driver Model: DS-OLS2-FPD bipolar, chopper driver at rated current (rms).
Motor's thrust will be changed with different voltage and driver. 50% thrust margin is recommended.

Size 17 (42mm) Series

Size 17 Double Stack Speed Thrust Curves

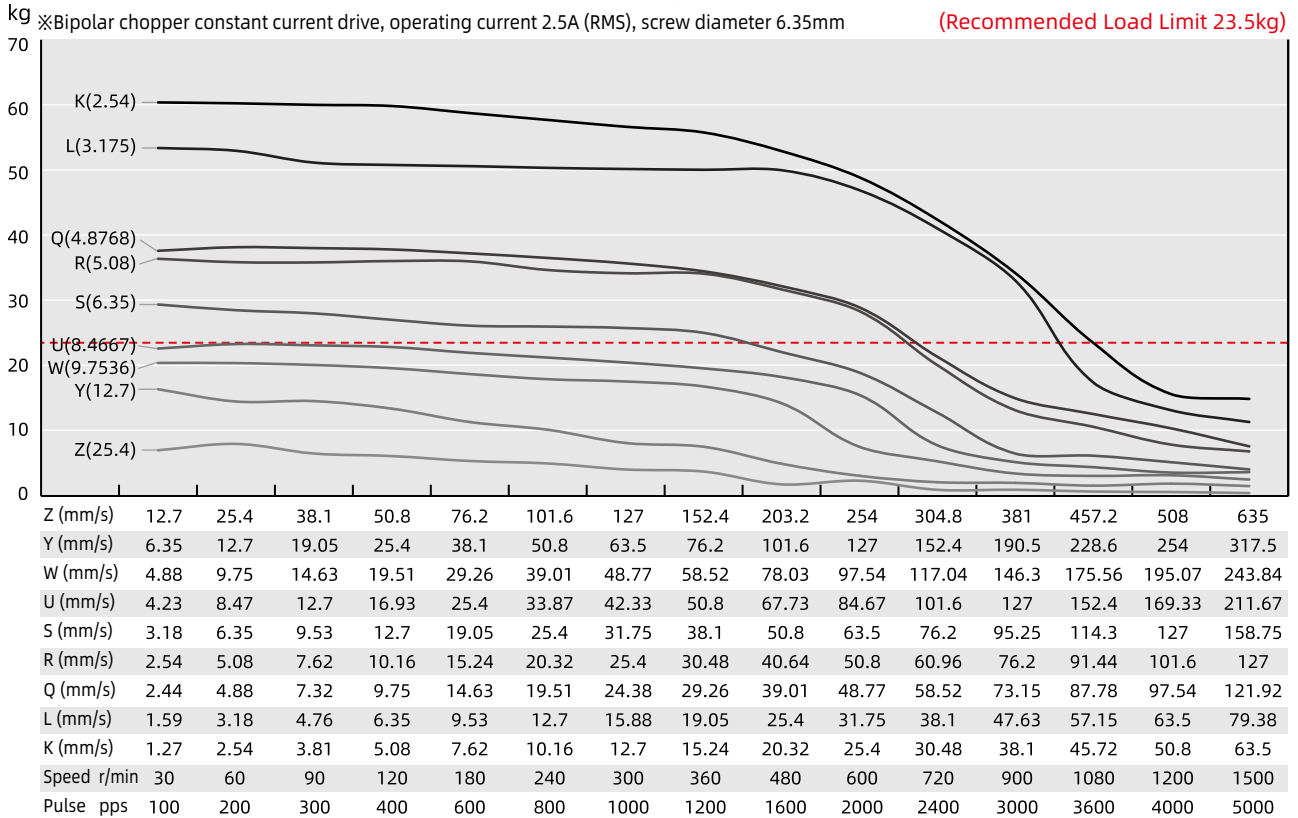

Size 17 Double Stack Speed Thrust Curves

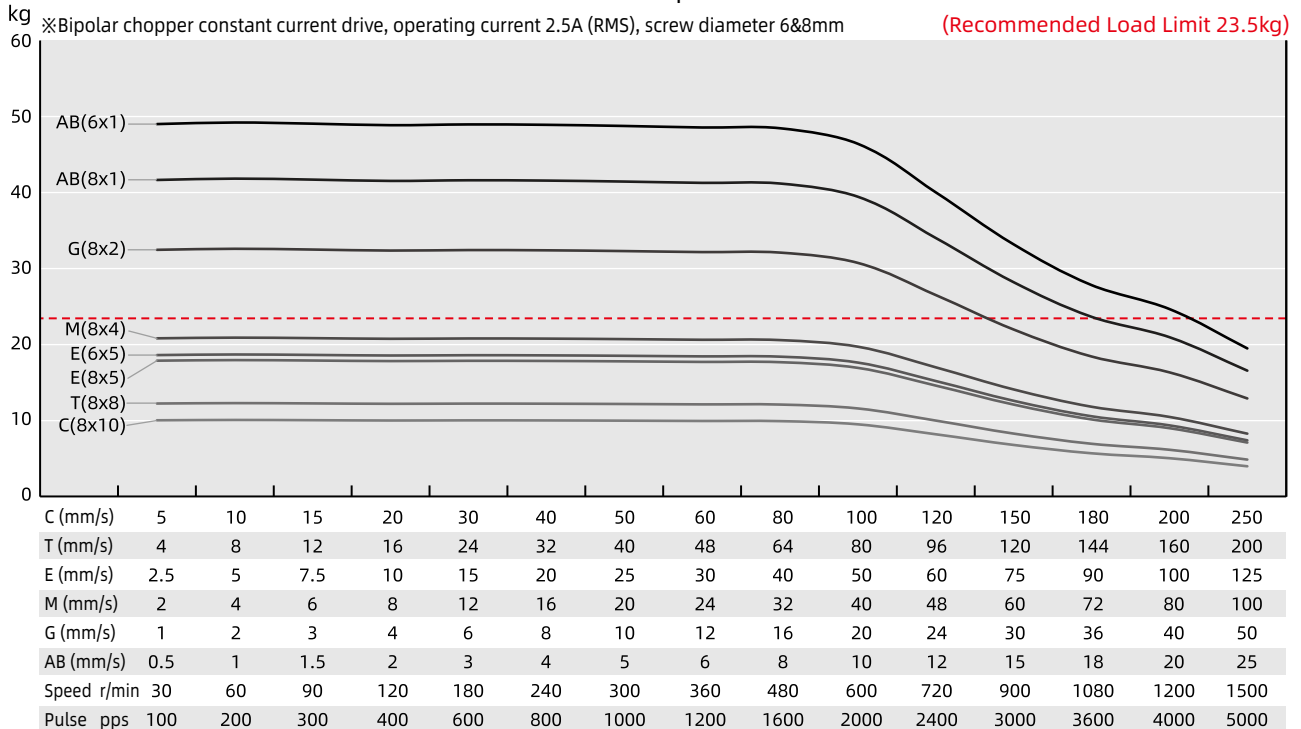

TEST CONDITION

Testing Voltage: 24Vdc, Driver Model: DS-OLS2-FPD bipolar, chopper driver at rated current (rms).
Motor's thrust will be changed with different voltage and driver. 50% thrust margin is recommended.

Size 23 (57mm) Series

Size 23 [57mm] Stepper Lead Screw Linear Actuator provides high performance, a longer working cycle, and is capable of 910N.

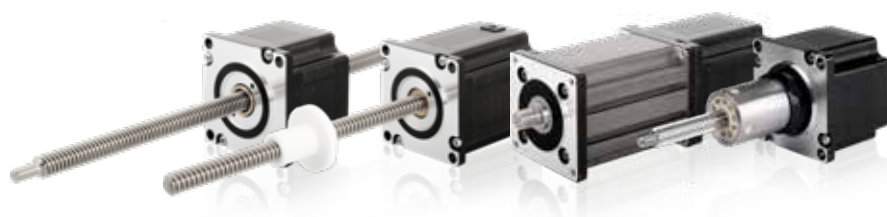

Motor Characteristics

| Motor | Voltage (V) | Current (A _{RMS}) | Resistance (Ω) | Inductance (mH) | Weight (g) | Lead Wire No. | Motor Length (mm) |
|---------|-------------|-----------------------------|----------------|-----------------|------------|---------------|-------------------|
| 23-2110 | 6.4 | 1 | 6.4 | 16.4 | 585 | 4 | 45 |
| 23-2120 | 3.5 | 2 | 1.75 | 4.1 | 585 | 4 | 45 |
| 23-2130 | 2.4 | 3 | 0.8 | 1.7 | 585 | 4 | 45 |
| 23-2210 | 11.5 | 1 | 11.5 | 32 | 880 | 4 | 65 |
| 23-2225 | 5 | 2.5 | 2 | 5.2 | 880 | 4 | 65 |
| 23-2240 | 2.8 | 4 | 0.7 | 2 | 880 | 4 | 65 |

Note : Motor Insulation Class B, Motor Temperature Rise 80°C, Ambient Temperature -20°C~55°C

Available Lead Screw and Travel per Step

| Screw Dia. (inch) | Screw Dia. (mm) | Lead (inch) | Lead (mm) | Lead Code | Travel Per Step @1.8° (mm)* | Travel Per Step @0.9° (mm)* |
|-------------------|-----------------|-------------|-----------|-----------|-----------------------------|-----------------------------|
| 0.375 | 9.525 | 0.025 | 0.635 | A | 0.0032 | 0.0016 |
| 0.375 | 9.525 | 0.05 | 1.27 | D | 0.0064 | 0.0032 |
| 0.375 | 9.525 | 0.0625 | 1.5875 | F | 0.0079 | 0.004 |
| 0.375 | 9.525 | 0.083 | 2.1167 | H | 0.0106 | 0.0053 |
| 0.375 | 9.525 | 0.1 | 2.54 | K | 0.0127 | 0.0064 |
| 0.375 | 9.525 | 0.125 | 3.175 | L | 0.0159 | 0.0079 |
| 0.375 | 9.525 | 0.167 | 4.2333 | P | 0.0212 | 0.0106 |
| 0.375 | 9.525 | 0.2 | 5.08 | R | 0.0254 | 0.0127 |
| 0.375 | 9.525 | 0.25 | 6.35 | S | 0.0318 | 0.0159 |
| 0.375 | 9.525 | 0.375 | 9.525 | V | 0.0476 | 0.0238 |
| 0.375 | 9.525 | 0.384 | 9.7536 | W | 0.0488 | 0.0244 |
| 0.375 | 9.525 | 0.4 | 10.16 | X | 0.0508 | 0.0254 |
| 0.375 | 9.525 | 0.5 | 12.7 | Y | 0.0635 | 0.0318 |
| 0.375 | 9.525 | 1 | 25.4 | Z | 0.127 | 0.0635 |
| 0.394/0.472 | 10/12 | 0.0787 | 2 | G | 0.01 | 0.005 |
| 0.394/0.472 | 10/12 | 0.3937 | 10 | C | 0.05 | 0.025 |
| 0.394 | 10 | 0.7874 | 20 | I | 0.1 | 0.05 |
| 0.472 | 12 | 0.1969 | 5 | E | 0.025 | 0.0125 |

* Motor wiring and screw lead could be customized according to customer's request

* Value Truncated

* 15.875mm diameter screw only can be applied in External Type

Size 23 (57mm) Series

■ Dimensional Drawings : External Actuator

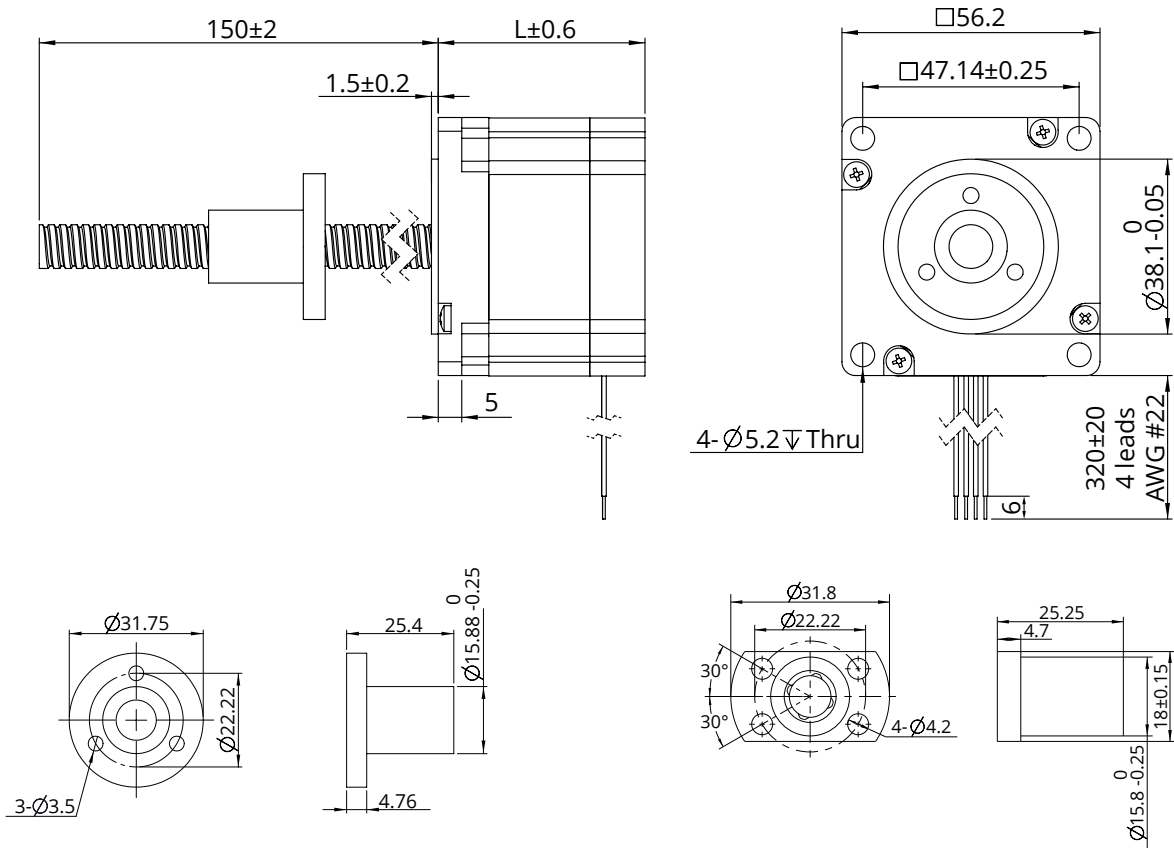

■ Dimensional Drawings : Non-Captive Actuator

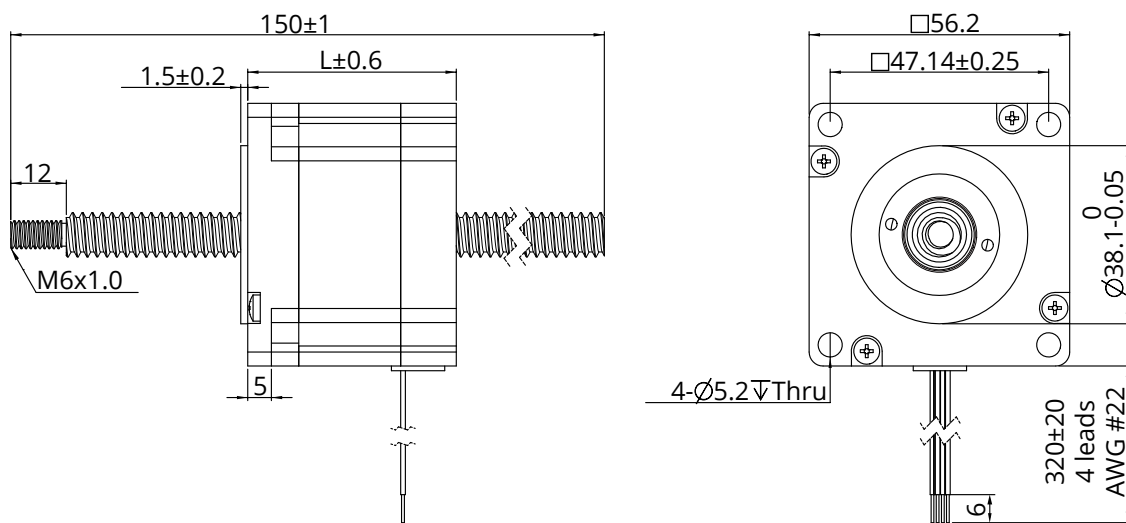

Note : All drawings are 1st Angle Projection - ISO Compliant (3D models available)

Size 23 (57mm) Series

Dimensional Drawings : Electric Cylinder (Captive) Actuator

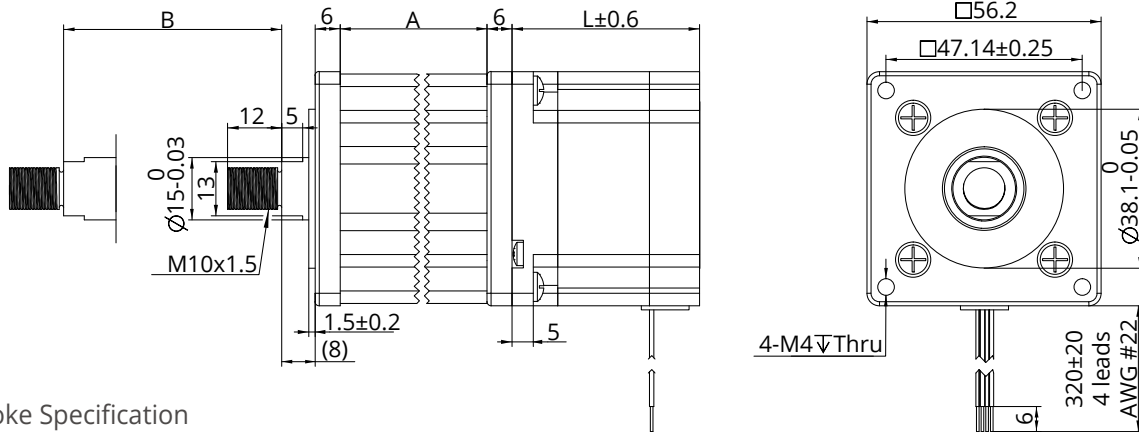

Stroke Specification

| Size A (mm) | Stroke B (mm) | Size L (mm) | |
|-------------|---------------|----------------------------|----------------------------|
| 45.7 | 12.7 | Single stack motor 45mm | Double stack motor 65mm |
| 52.05 | 19.05 | | |
| 58.4 | 25.4 | | |
| 64.8 | 31.8 | | |
| 71.1 | 38.1 | | |
| 83.8 | 50.8 | | |
| 96.5 | 63.5 | | |

Dimensional Drawings : Kaptive Actuator

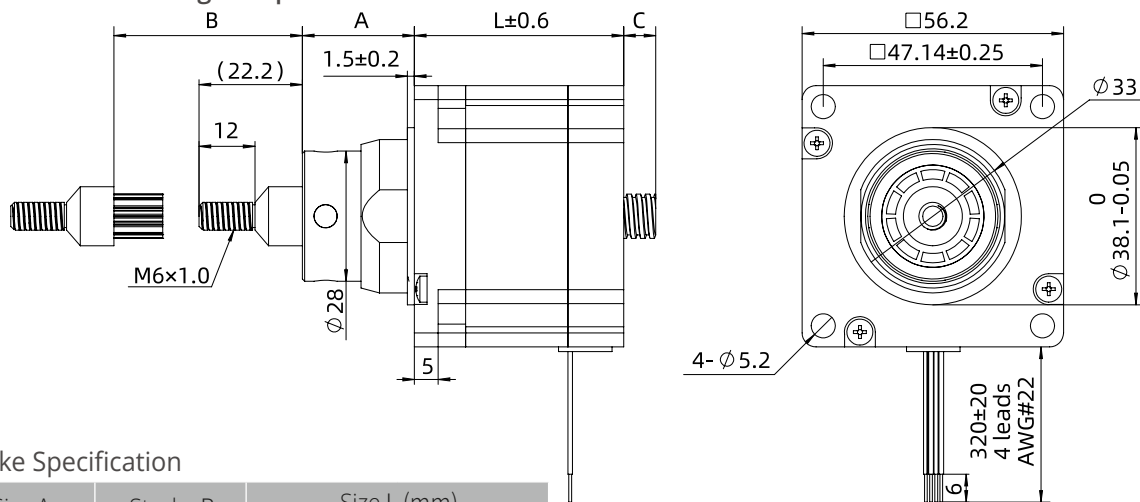

Stroke Specification

| Size A (mm) | Stroke B (mm) | Size L (mm) | |
|-------------|---------------|-------------|-------|
| | | L=45 | L=65 |
| 24.2 | 12.7 | 5.8 | 0 |
| 30.55 | 19.05 | 11.65 | 1.65 |
| 36.9 | 25.4 | 18 | 8 |
| 43.25 | 31.75 | 24.35 | 14.35 |
| 49.6 | 38.1 | 30.7 | 20.7 |
| 62.3 | 50.8 | 43.4 | 33.4 |
| 75 | 63.5 | 56.1 | 46.1 |

For stroke customization, please contact DINGS' or local representative.

Size 23 (57mm) Series

Speed Thrust Curves

Size 23 Single Stack Speed Thrust Curves

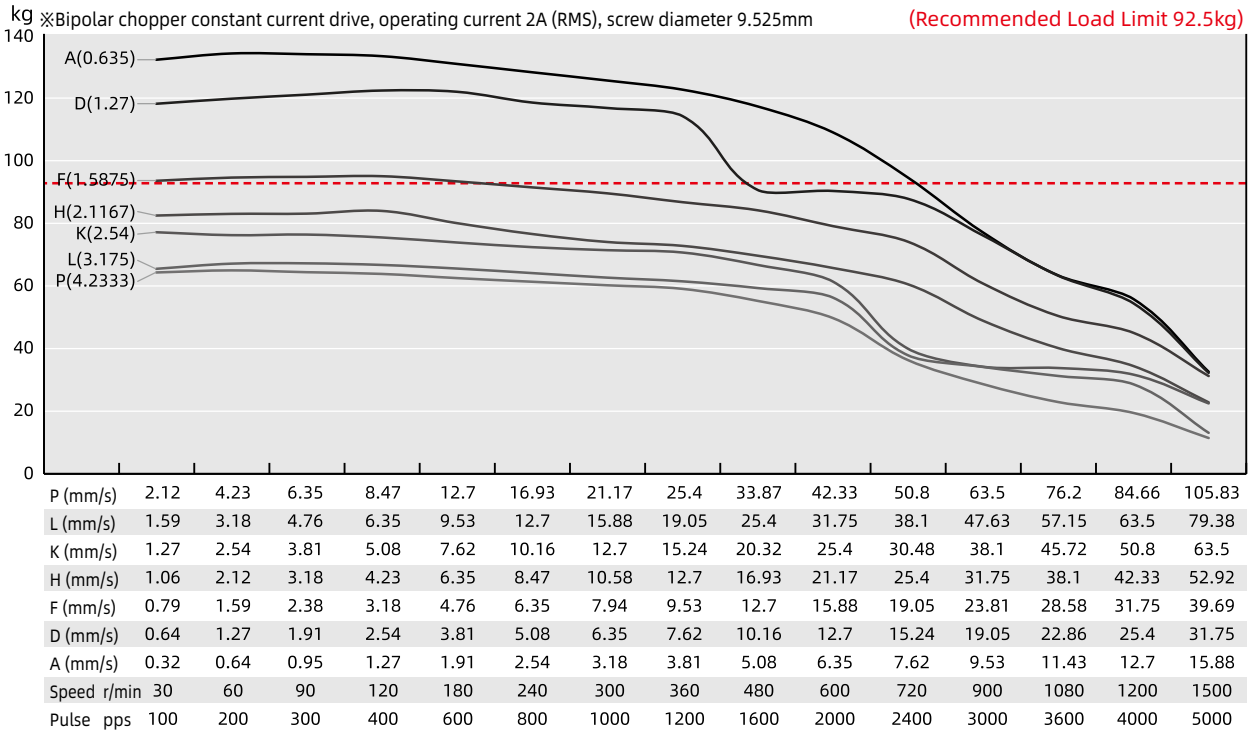

Size 23 Single Stack Speed Thrust Curves

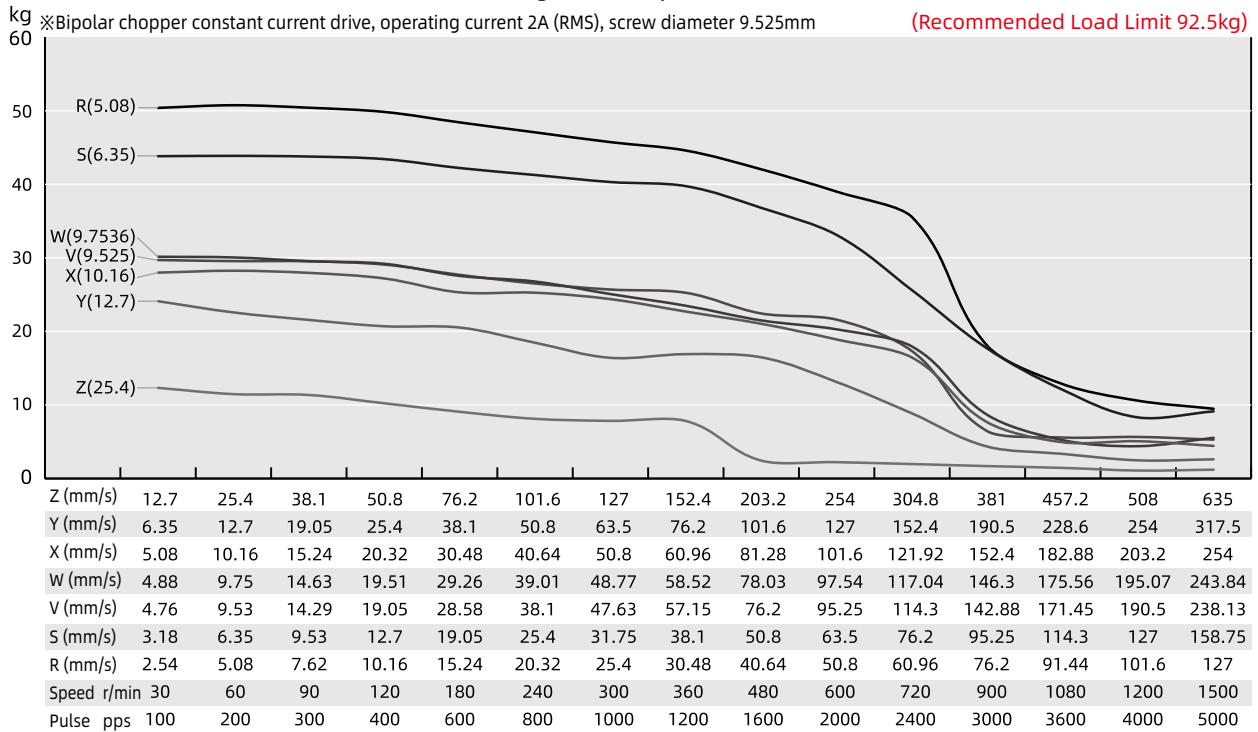

TEST CONDITION

Testing Voltage: 48Vdc, Driver Model: DS-OLS4-FPD bipolar, chopper driver at rated current (rms).
Motor's thrust will be changed with different voltage and driver. 50% thrust margin is recommended.

Size 23 (57mm) Series

Size 23 Single Stack Speed Thrust Curves

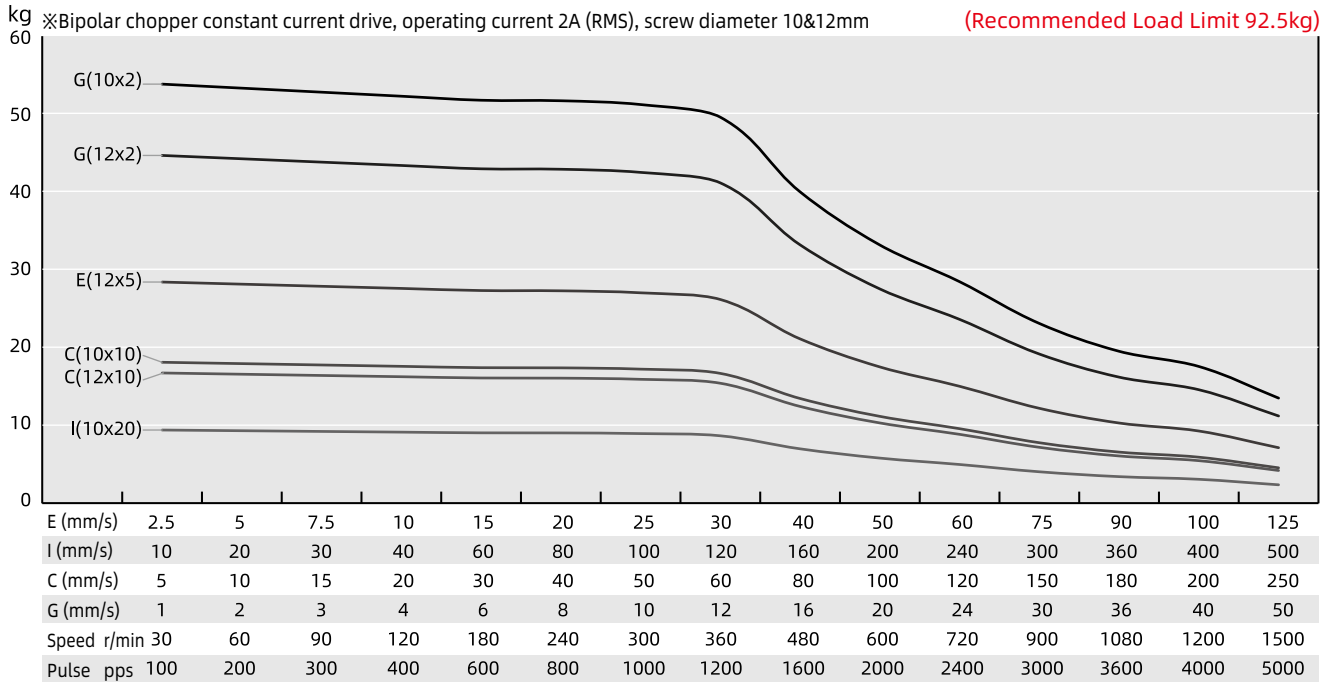

Size 23 Double Stack Speed Thrust Curves

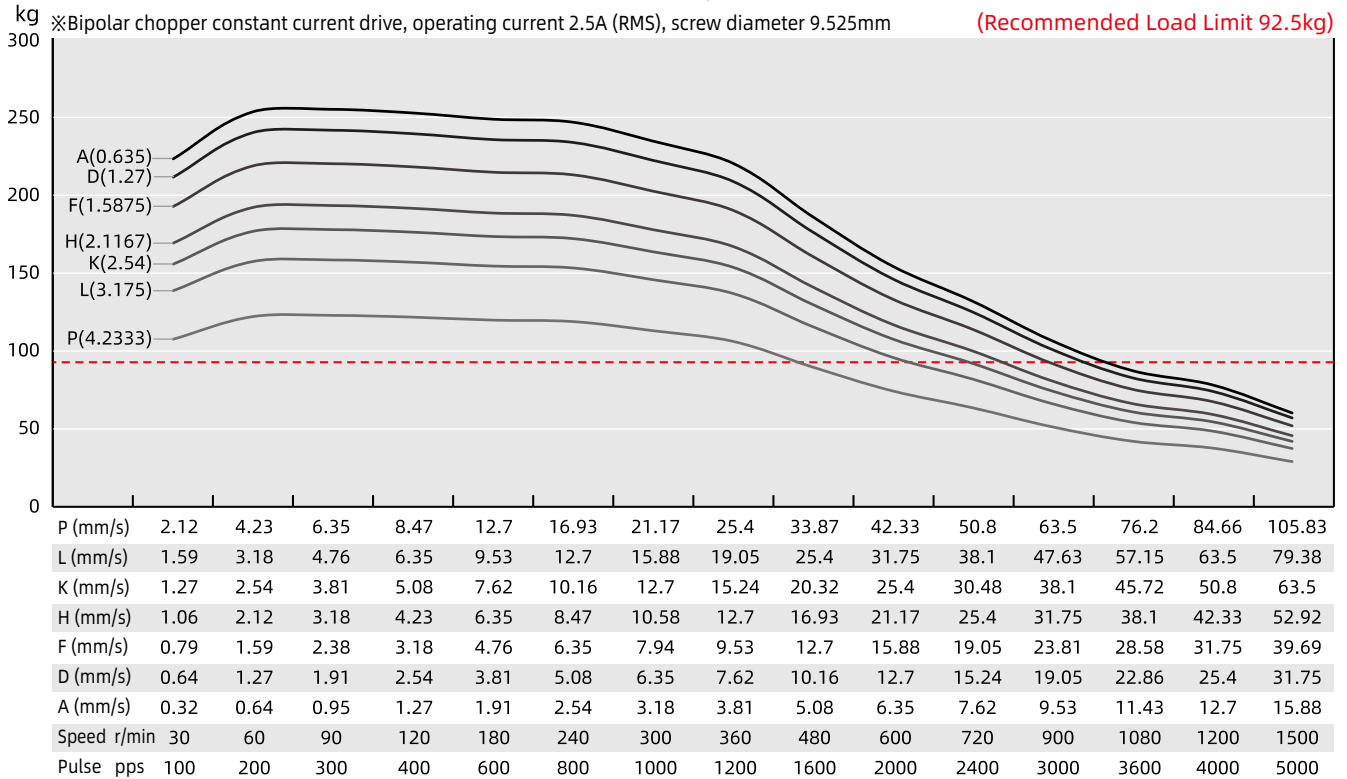

TEST CONDITION

Testing Voltage: 48Vdc, Driver Model: DS-OLS4-FPD bipolar, chopper driver at rated current (rms).
Motor's thrust will be changed with different voltage and driver. 50% thrust margin is recommended.

Size 23 (57mm) Series

Size 23 Double Stack Speed Thrust Curves

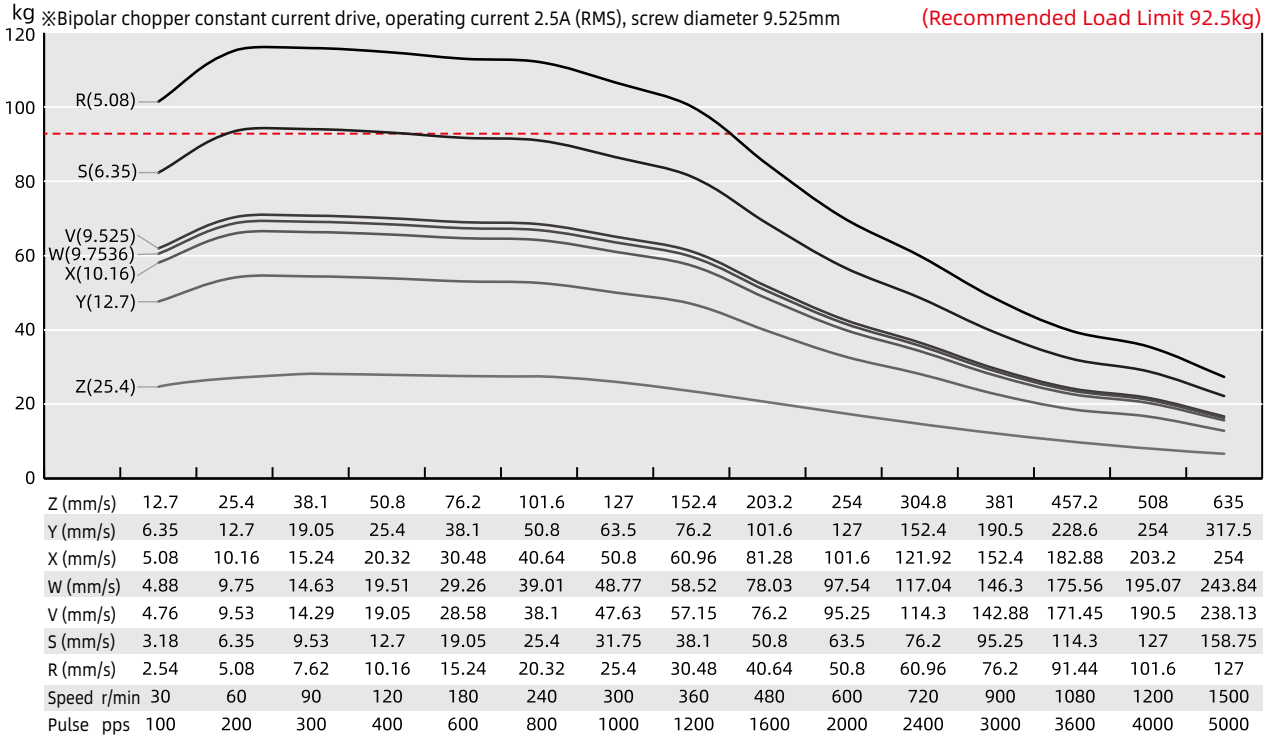

Size 23 Double Stack Speed Thrust Curves

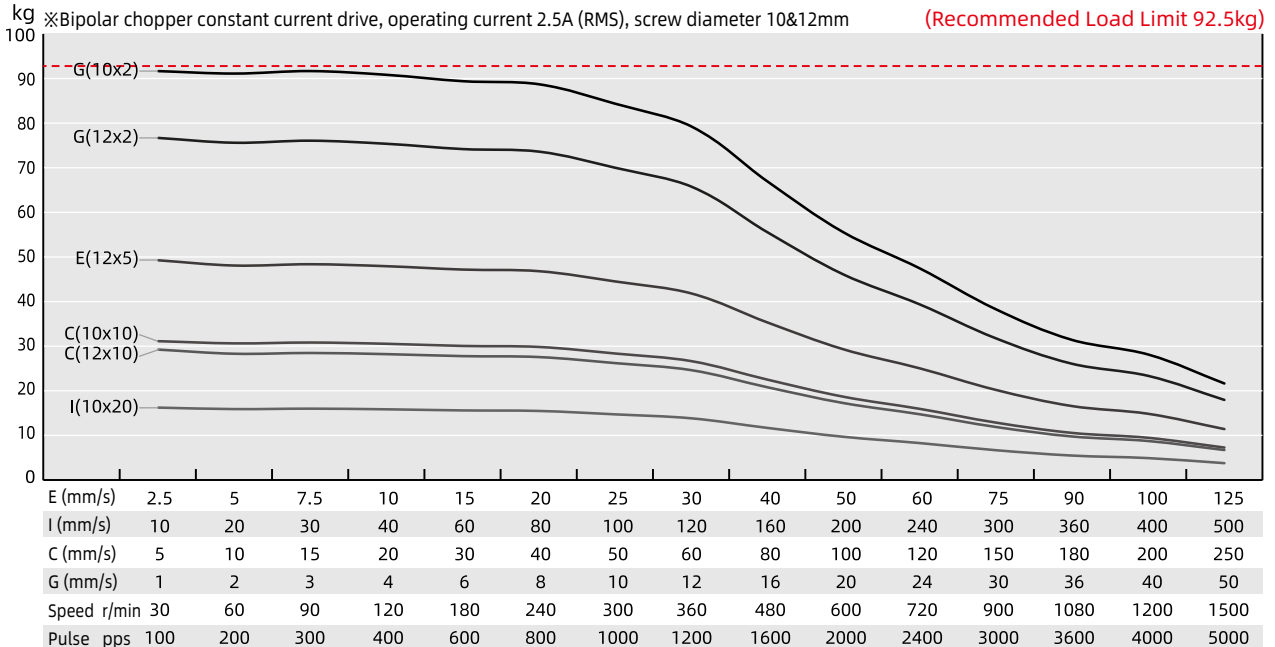

TEST CONDITION

Testing Voltage: 48Vdc, Driver Model: DS-OLS4-FPD bipolar, chopper driver at rated current (rms).
Motor's thrust will be changed with different voltage and driver. 50% thrust margin is recommended.

Size 24 (60mm) Series

Size 24 [60mm] Stepper Lead Screw Linear Actuator provides high performance, a longer working cycle, and is capable of 1050N.

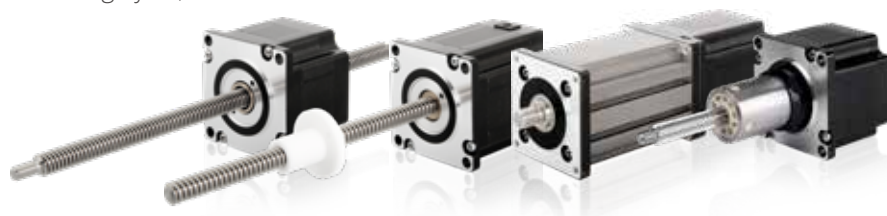

Motor Characteristics

| Motor | Voltage (V) | Current (A _{RMS}) | Resistance (Ω) | Inductance (mH) | Weight (g) | Lead Wire No. | Motor Length (mm) |
|---------|-------------|-----------------------------|----------------|-----------------|------------|---------------|-------------------|
| 24-2120 | 3 | 2 | 1.5 | 3.9 | 680 | 4 | 47 |
| 24-2130 | 1.8 | 3 | 0.6 | 1.6 | 680 | 4 | 47 |
| 24-2140 | 1.6 | 4 | 0.4 | 0.9 | 680 | 4 | 47 |
| 24-2230 | 3 | 3 | 1 | 3.4 | 1080 | 4 | 68.3 |
| 24-2240 | 2.4 | 4 | 0.6 | 1.9 | 1080 | 4 | 68.3 |
| 24-2250 | 1.5 | 5 | 0.3 | 1.2 | 1080 | 4 | 68.3 |

Note : Motor Insulation Class B, Motor Temperature Rise 80°C, Ambient Temperature -20°C~55°C

Available Lead Screw and Travel per Step

| Screw Dia. (inch) | Screw Dia. (mm) | Lead (inch) | Lead (mm) | Lead Code | Travel Per Step @1.8° (mm)* | Travel Per Step @0.9° (mm)* |
|-------------------|-----------------|-------------|-----------|-----------|-----------------------------|-----------------------------|
| 0.375 | 9.525 | 0.025 | 0.635 | A | 0.0032 | 0.0016 |
| 0.375 | 9.525 | 0.05 | 1.27 | D | 0.0064 | 0.0032 |
| 0.375 | 9.525 | 0.0625 | 1.5875 | F | 0.0079 | 0.004 |
| 0.375 | 9.525 | 0.083 | 2.1167 | H | 0.0106 | 0.0053 |
| 0.375 | 9.525 | 0.1 | 2.54 | K | 0.0127 | 0.0064 |
| 0.375 | 9.525 | 0.125 | 3.175 | L | 0.0159 | 0.0079 |
| 0.375 | 9.525 | 0.167 | 4.2333 | P | 0.0212 | 0.0106 |
| 0.375 | 9.525 | 0.2 | 5.08 | R | 0.0254 | 0.0127 |
| 0.375 | 9.525 | 0.25 | 6.35 | S | 0.0318 | 0.0159 |
| 0.375 | 9.525 | 0.375 | 9.525 | V | 0.0476 | 0.0238 |
| 0.375 | 9.525 | 0.384 | 9.7536 | W | 0.0488 | 0.0244 |
| 0.375 | 9.525 | 0.4 | 10.16 | X | 0.0508 | 0.0254 |
| 0.375 | 9.525 | 0.5 | 12.7 | Y | 0.0635 | 0.0318 |
| 0.375 | 9.525 | 1 | 25.4 | Z | 0.127 | 0.0635 |
| 0.394/0.472 | 10/12 | 0.0787 | 2 | G | 0.01 | 0.005 |
| 0.394/0.472 | 10/12 | 0.3937 | 10 | C | 0.05 | 0.025 |
| 0.394 | 10 | 0.7874 | 20 | I | 0.1 | 0.05 |
| 0.472 | 12 | 0.1969 | 5 | E | 0.025 | 0.0125 |

* Motor wiring and screw lead could be customized according to customer's request

* Value Truncated

* 15.875mm diameter screw only can be applied in External Type

Size 24 (60mm) Series

Dimensional Drawings : External Actuator

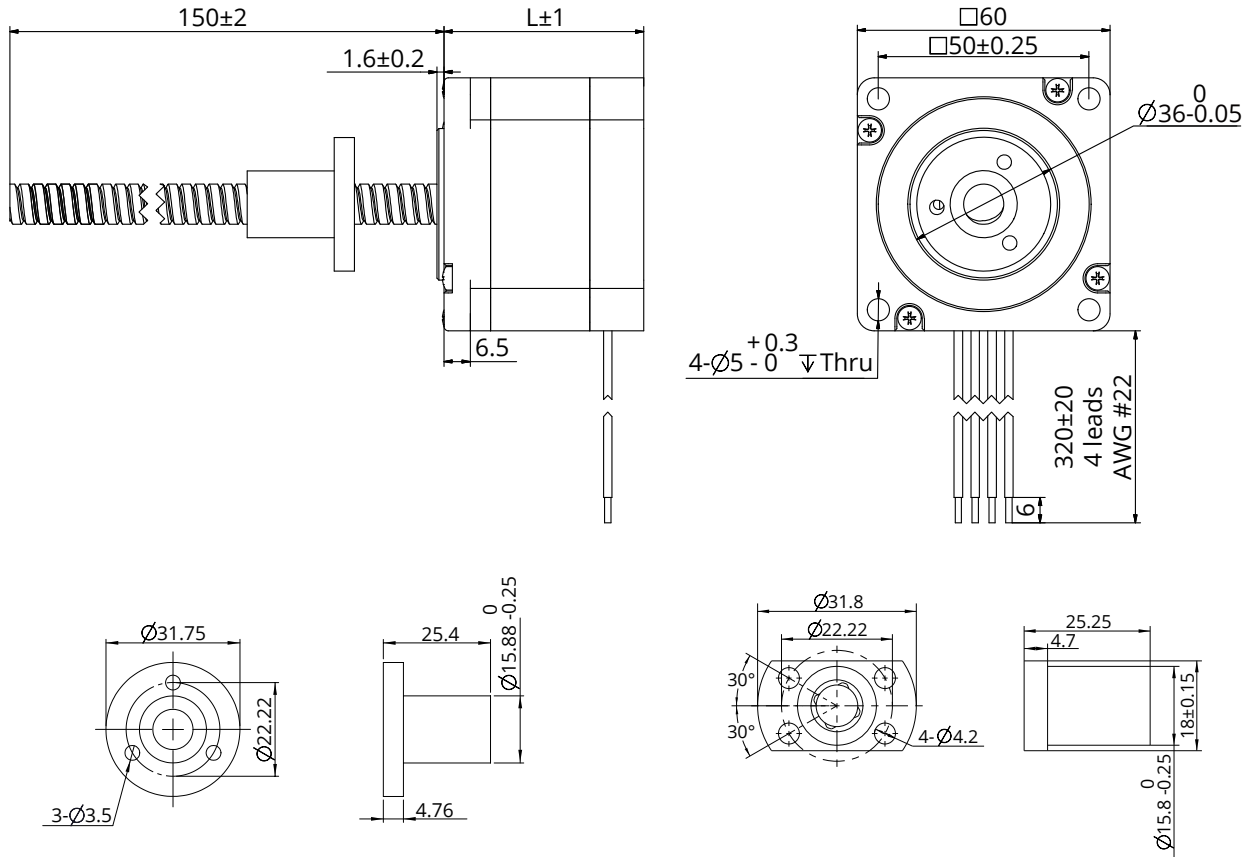

Dimensional Drawings : Non-Captive Actuator

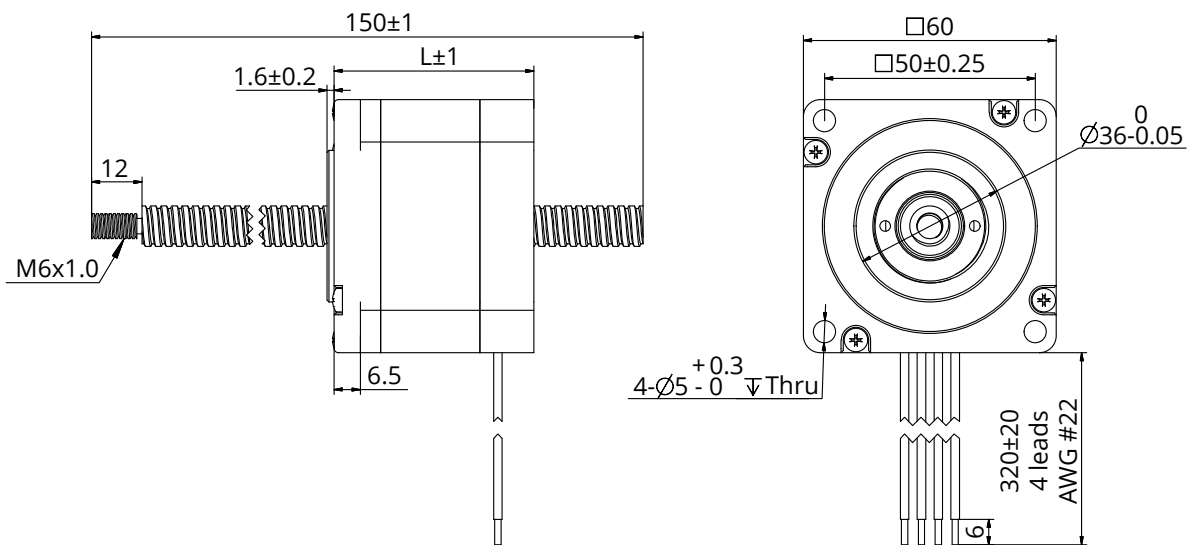

Note : All drawings are 1st Angle Projection - ISO Compliant (3D models available)

Size 24 (60mm) Series

Speed Thrust Curves

Size 24 Single Stack Speed Thrust Curves

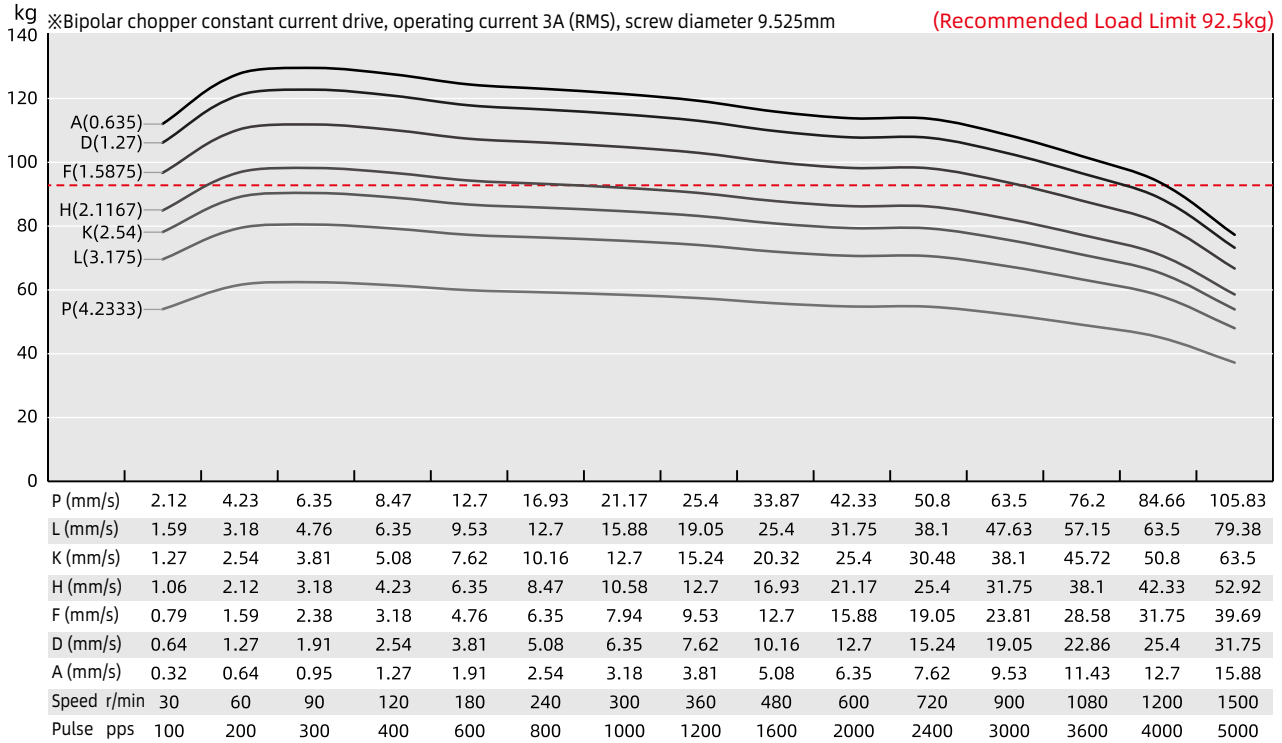

Size 24 Single Stack Speed Thrust Curves

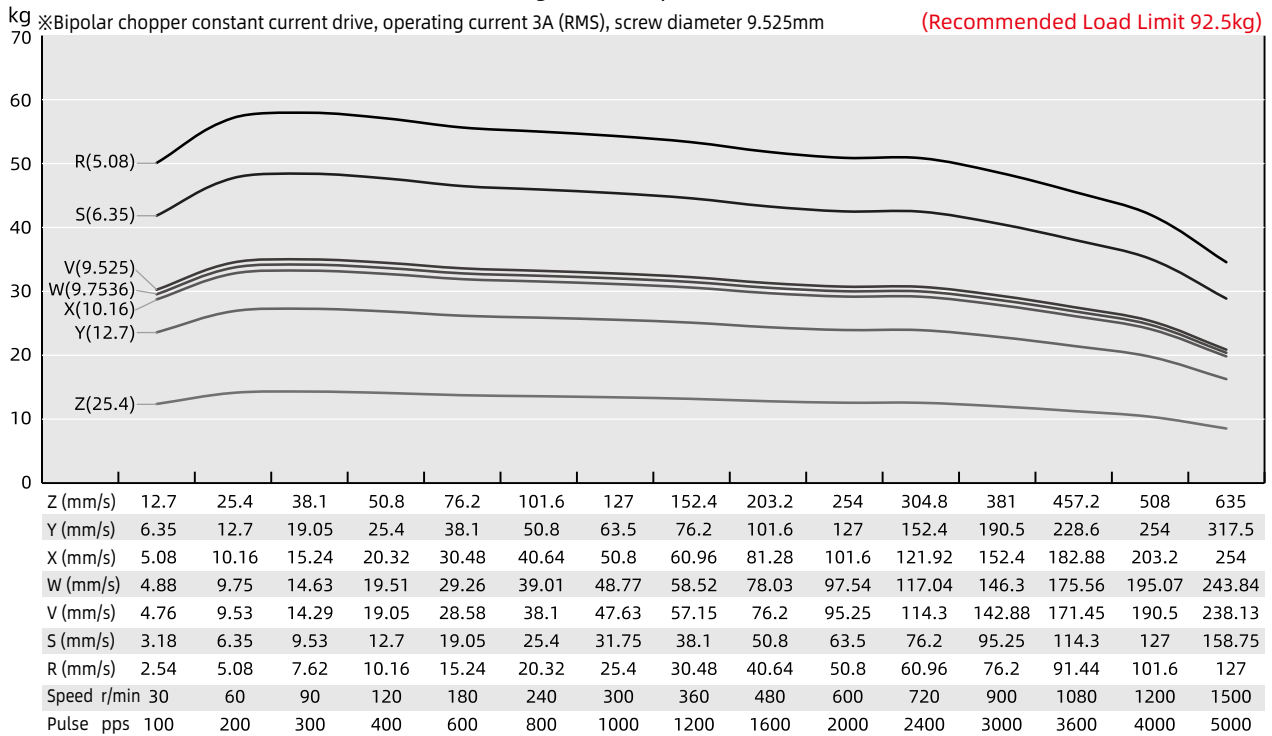

TEST CONDITION

Testing Voltage: 48Vdc, Driver Model: DS-OLS4-FPD bipolar, chopper driver at rated current (rms).
Motor's thrust will be changed with different voltage and driver. 50% thrust margin is recommended.

Size 24 (60mm) Series

Size 24 Single Stack Speed Thrust Curves

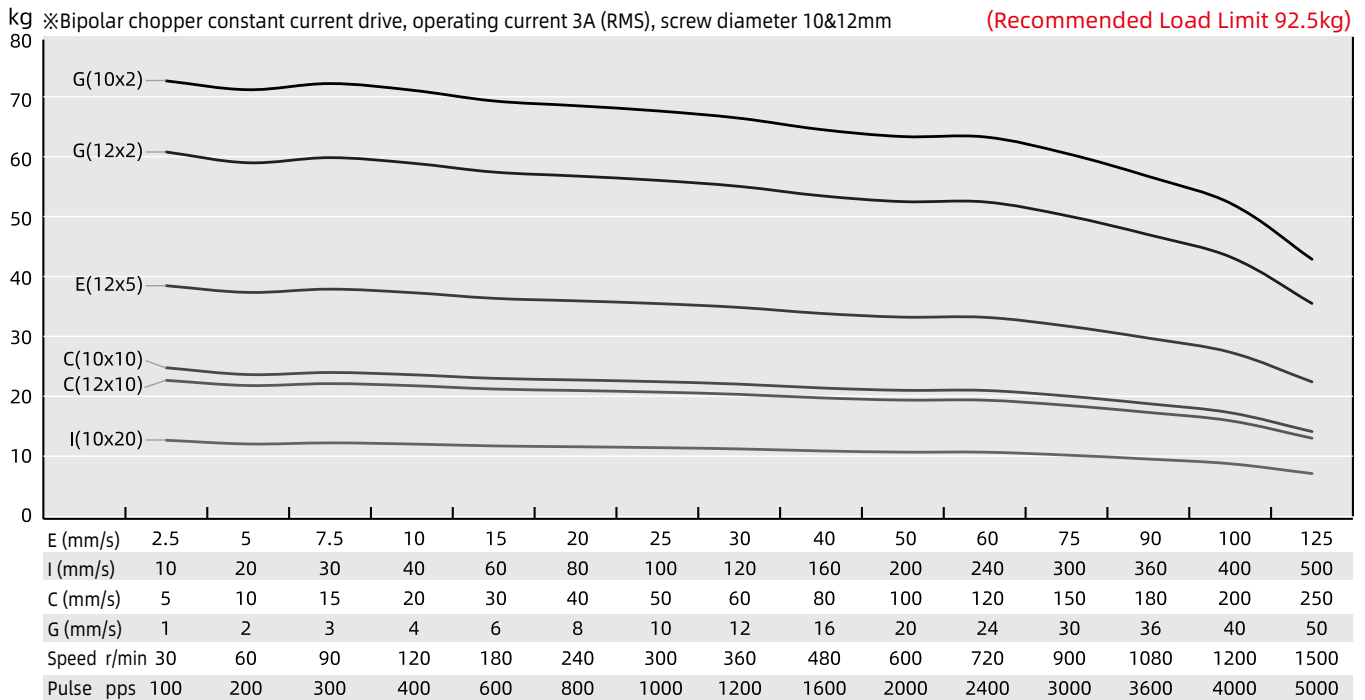

Size 24 Double Stack Speed Thrust Curves

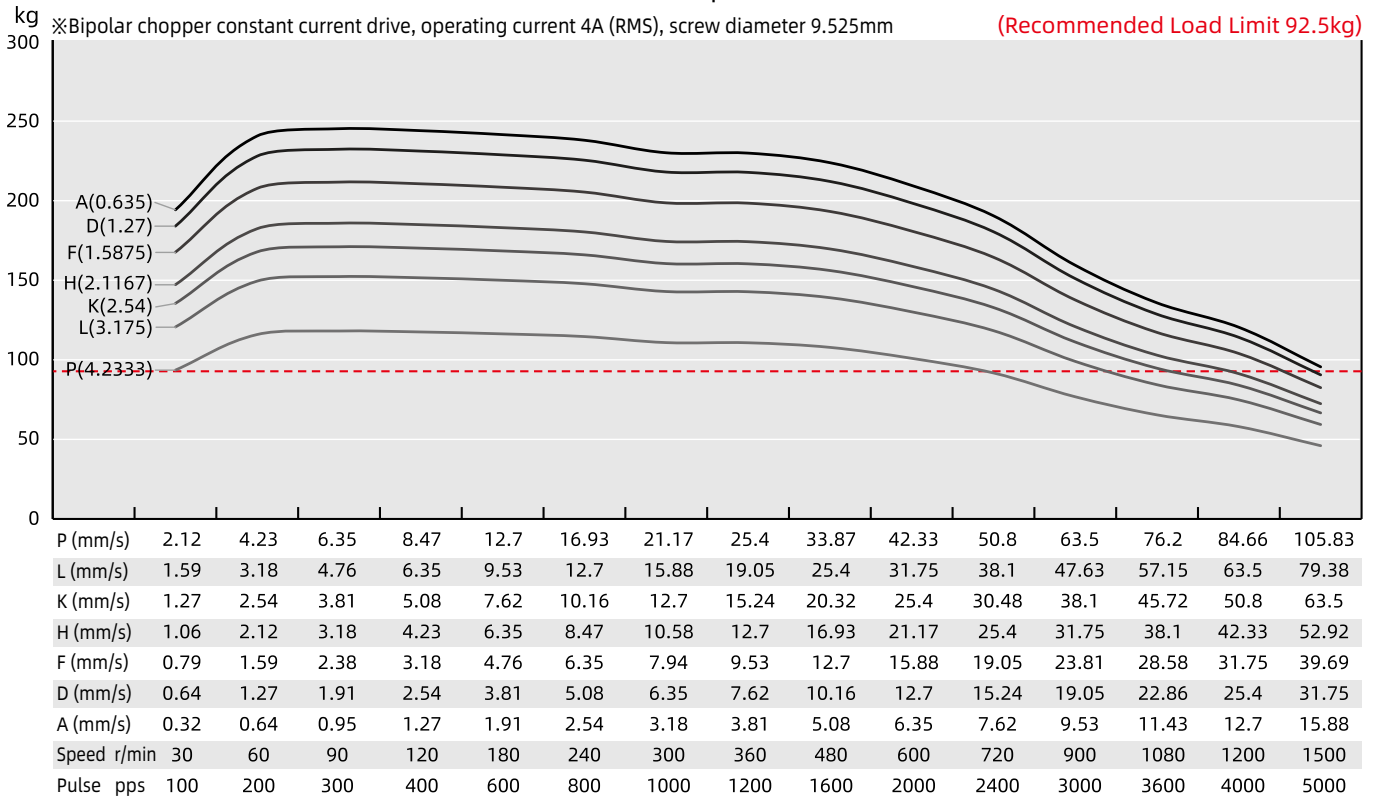

TEST CONDITION

Testing Voltage: 48Vdc, Driver Model: DS-OLS4-FPD bipolar, chopper driver at rated current (rms).
Motor's thrust will be changed with different voltage and driver. 50% thrust margin is recommended.

Size 24 (60mm) Series

Size 24 Double Stack Speed Thrust Curves

kg ※Bipolar chopper constant current drive, operating current 4A (RMS), screw diameter 9.525mm (Recommended Load Limit 92.5kg)

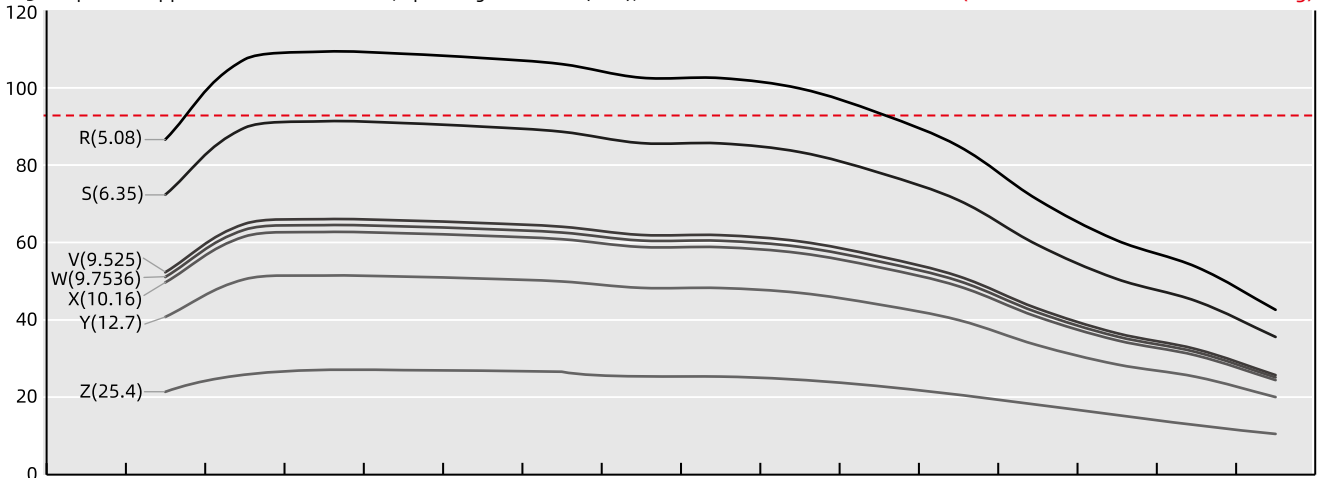

| | | | | | | | | | | | | | | | |
|-------------|------|-------|-------|-------|-------|-------|-------|-------|-------|-------|--------|--------|--------|--------|--------|
| Z (mm/s) | 12.7 | 25.4 | 38.1 | 50.8 | 76.2 | 101.6 | 127 | 152.4 | 203.2 | 254 | 304.8 | 381 | 457.2 | 508 | 635 |
| Y (mm/s) | 6.35 | 12.7 | 19.05 | 25.4 | 38.1 | 50.8 | 63.5 | 76.2 | 101.6 | 127 | 152.4 | 190.5 | 228.6 | 254 | 317.5 |
| X (mm/s) | 5.08 | 10.16 | 15.24 | 20.32 | 30.48 | 40.64 | 50.8 | 60.96 | 81.28 | 101.6 | 121.92 | 152.4 | 182.88 | 203.2 | 254 |
| W (mm/s) | 4.88 | 9.75 | 14.63 | 19.51 | 29.26 | 39.01 | 48.77 | 58.52 | 78.03 | 97.54 | 117.04 | 146.3 | 175.56 | 195.07 | 243.84 |
| V (mm/s) | 4.76 | 9.53 | 14.29 | 19.05 | 28.58 | 38.1 | 47.63 | 57.15 | 76.2 | 95.25 | 114.3 | 142.88 | 171.45 | 190.5 | 238.13 |
| S (mm/s) | 3.18 | 6.35 | 9.53 | 12.7 | 19.05 | 25.4 | 31.75 | 38.1 | 50.8 | 63.5 | 76.2 | 95.25 | 114.3 | 127 | 158.75 |
| R (mm/s) | 2.54 | 5.08 | 7.62 | 10.16 | 15.24 | 20.32 | 25.4 | 30.48 | 40.64 | 50.8 | 60.96 | 76.2 | 91.44 | 101.6 | 127 |
| Speed r/min | 30 | 60 | 90 | 120 | 180 | 240 | 300 | 360 | 480 | 600 | 720 | 900 | 1080 | 1200 | 1500 |
| Pulse pps | 100 | 200 | 300 | 400 | 600 | 800 | 1000 | 1200 | 1600 | 2000 | 2400 | 3000 | 3600 | 4000 | 5000 |

Size 24 Double Stack Speed Thrust Curves

kg ※Bipolar chopper constant current drive, operating current 4A (RMS), screw diameter 10&12mm (Recommended Load Limit 92.5kg)

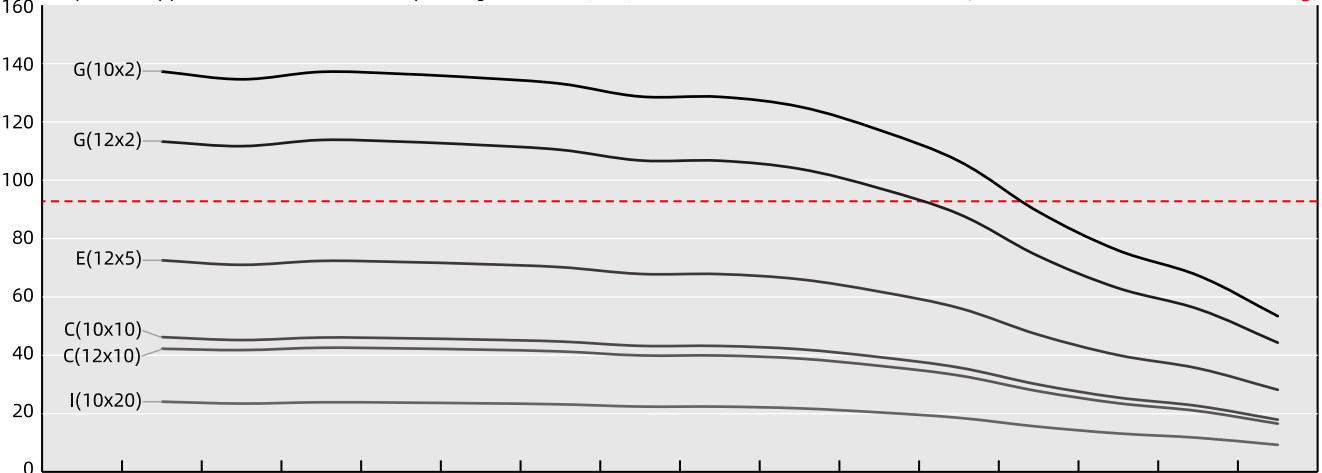

| | | | | | | | | | | | | | | | |
|-------------|-----|-----|-----|-----|-----|-----|------|------|------|------|------|------|------|------|------|
| E (mm/s) | 2.5 | 5 | 7.5 | 10 | 15 | 20 | 25 | 30 | 40 | 50 | 60 | 75 | 90 | 100 | 125 |
| I (mm/s) | 10 | 20 | 30 | 40 | 60 | 80 | 100 | 120 | 160 | 200 | 240 | 300 | 360 | 400 | 500 |
| C (mm/s) | 5 | 10 | 15 | 20 | 30 | 40 | 50 | 60 | 80 | 100 | 120 | 150 | 180 | 200 | 250 |
| G (mm/s) | 1 | 2 | 3 | 4 | 6 | 8 | 10 | 12 | 16 | 20 | 24 | 30 | 36 | 40 | 50 |
| Speed r/min | 30 | 60 | 90 | 120 | 180 | 240 | 300 | 360 | 480 | 600 | 720 | 900 | 1080 | 1200 | 1500 |
| Pulse pps | 100 | 200 | 300 | 400 | 600 | 800 | 1000 | 1200 | 1600 | 2000 | 2400 | 3000 | 3600 | 4000 | 5000 |

TEST CONDITION

Testing Voltage: 48Vdc, Driver Model: DS-OLS4-FPD bipolar, chopper driver at rated current (rms). Motor's thrust will be changed with different voltage and driver. 50% thrust margin is recommended.

Size 34 (86mm) Series

Size 34 [86mm] Stepper Lead Screw Linear Actuator is our biggest in size, and can provide up to 2270N of continuous thrust.

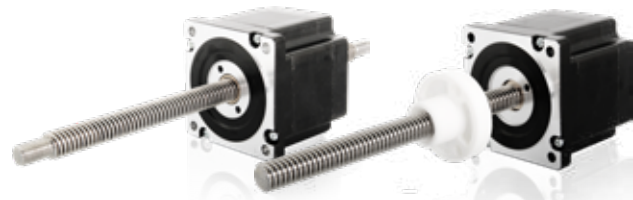

Motor Characteristics

| Motor | Voltage (V) | Current (A [RMS]) | Resistance (Ω) | Inductance (mH) | Weight (g) | Lead Wire No. | Motor Length (mm) |
|---------|-------------|-------------------|-------------------------|-----------------|------------|---------------|-------------------|
| 34-2113 | 12 | 1.3 | 9.2 | 71 | 2370 | 4 | 76 |
| 34-2130 | 5.7 | 3 | 1.9 | 15 | 2370 | 4 | 76 |
| 34-2155 | 2.85 | 5.5 | 0.52 | 4.5 | 2370 | 4 | 76 |

Note : Motor Insulation Class B, Motor Temperature Rise 80°C, Ambient Temperature -20°C~55°C

Available Lead Screw and Travel per Step

| Screw Dia. (inch) | Screw Dia. (mm) | Lead (inch) | Lead (mm) | Lead Code | Travel Per Step @1.8° (mm)* |
|-------------------|-----------------|-------------|-----------|-----------|-----------------------------|
| 0.625 | 15.875 | 0.1 | 2.54 | K | 0.0127 |
| 0.625 | 15.875 | 0.125 | 3.175 | L | 0.0159 |
| 0.625 | 15.875 | 0.2 | 5.08 | R | 0.0254 |
| 0.625 | 15.875 | 0.25 | 6.35 | S | 0.0318 |
| 0.625 | 15.875 | 0.5 | 12.7 | Y | 0.0635 |
| 0.625 | 15.875 | 1 | 25.4 | Z | 0.127 |

* Motor wiring and screw lead could be customized according to customer's request

* Value Truncated

Dimensional Drawings : External Actuator

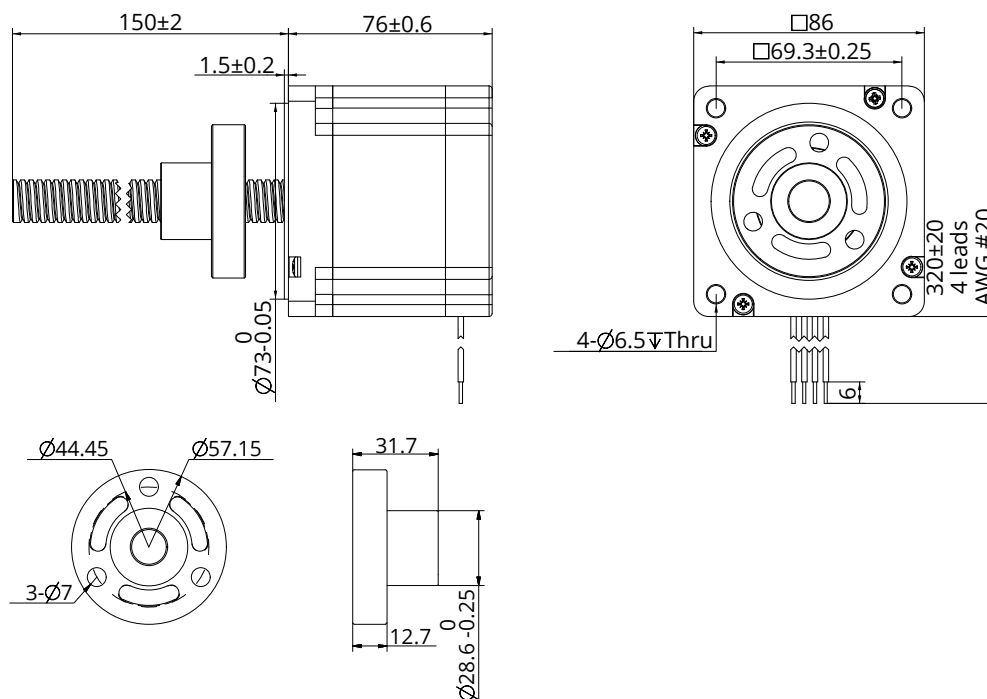

Note : All drawings are 1st Angle Projection - ISO Compliant (3D models available)

Size 34 (86mm) Series

Dimensional Drawings : Non-Captive Actuator

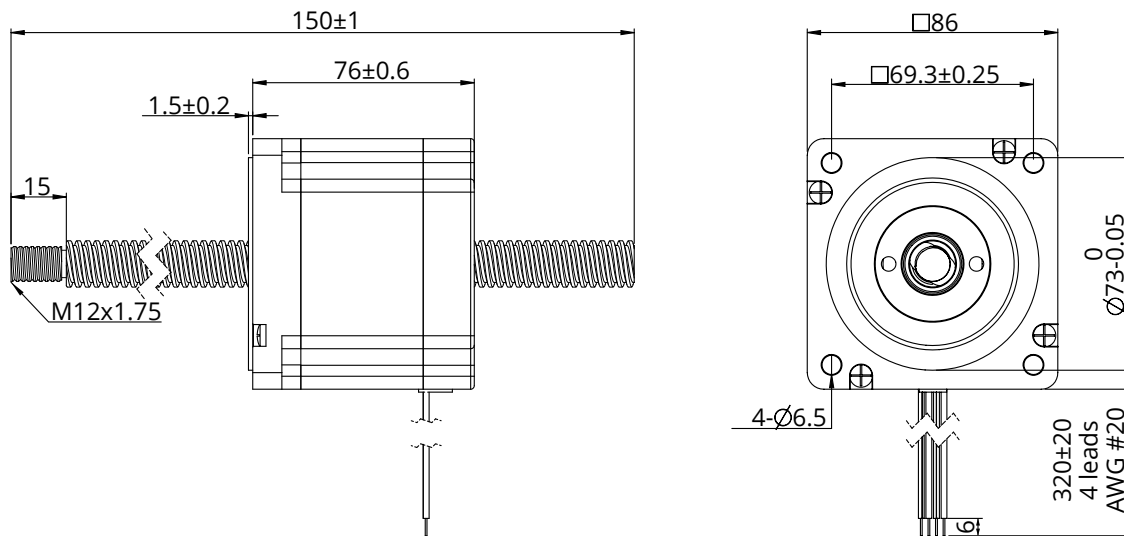

Speed Thrust Curves

Size 34 Single Stack Speed Thrust Curves

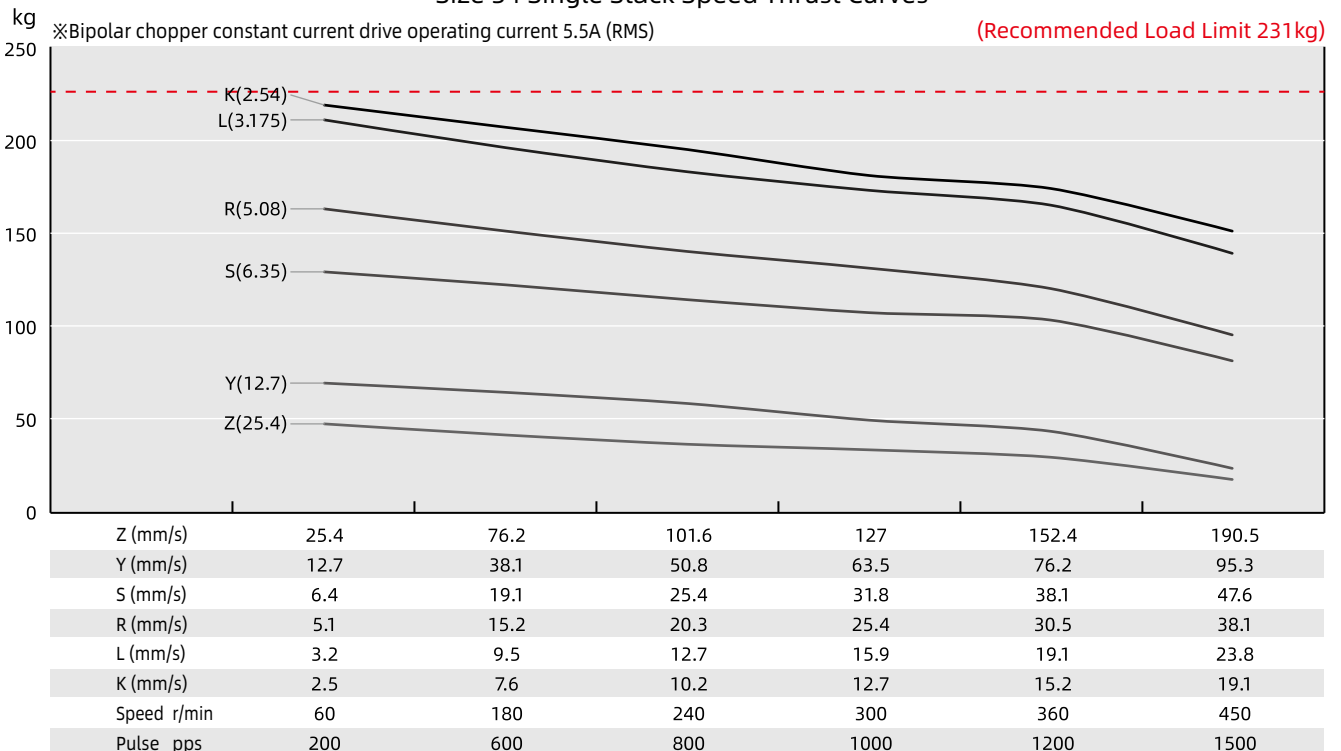



TEST CONDITION

Testing Voltage: 48Vdc, Driver Model: DS-OLS8-FPD bipolar, chopper driver at rated current (rms).
Motor's thrust will be changed with different voltage and driver. 50% thrust margin is recommended.

Accessories and Options

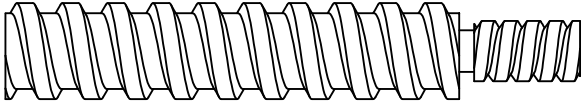
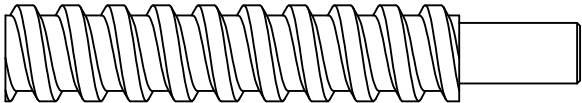
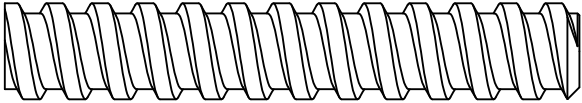
Screw End Machining

| | | |
|---|--------------|---|
|  | Threaded End | <p>Screw end machining depends on screw diameter. For customized screw end machining are available, please contact DINGS' representatives for more details.</p> |
|  | Smooth End | |
|  | None | |
|  | Customized | |

Accessories and Options

External Actuator Anti-Backlash Nut

Torsion Spring Anti-Backlash Nut

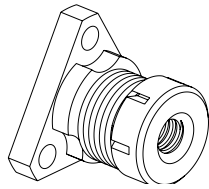
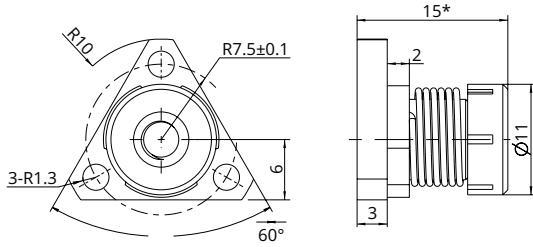

Size 8 (20mm) & Size 11 (28mm)

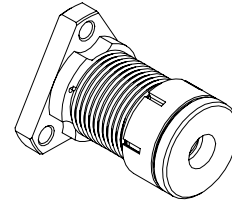
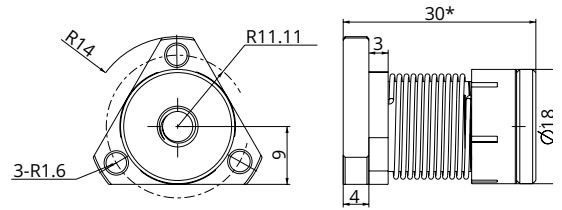

Size 14 (35mm) & Size 17 (42mm)

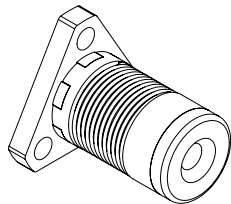
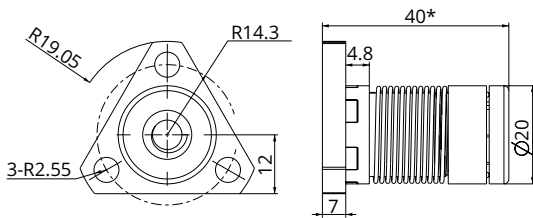

Size 23 (57mm)

Compression Spring Anti-Backlash Nut

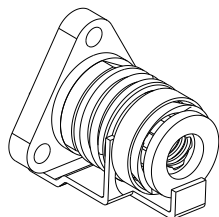
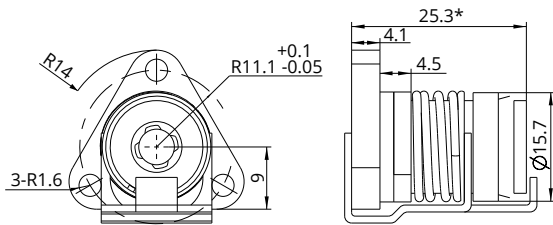

Size 14 (35mm) & Size 17 (42mm)

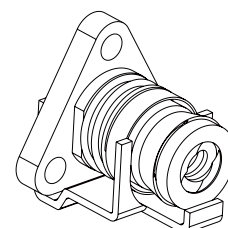
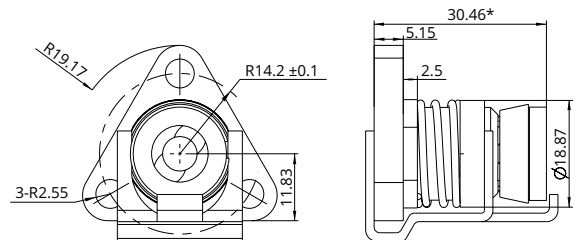

Size 23 (57mm)

* According to different screw lead code selection, length of Anti-Backlash nut can be changed

Accessories and Options

Non-Captive Actuator Anti-Backlash Nut

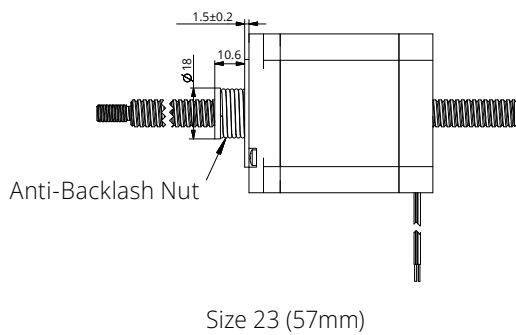
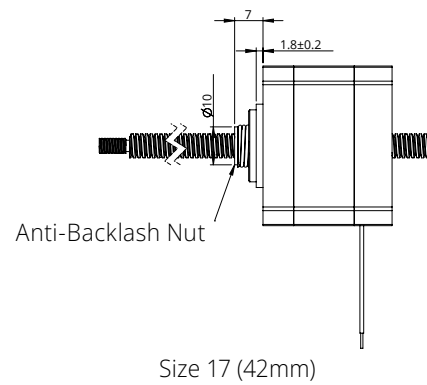
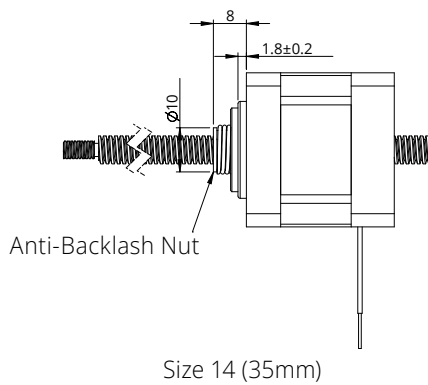
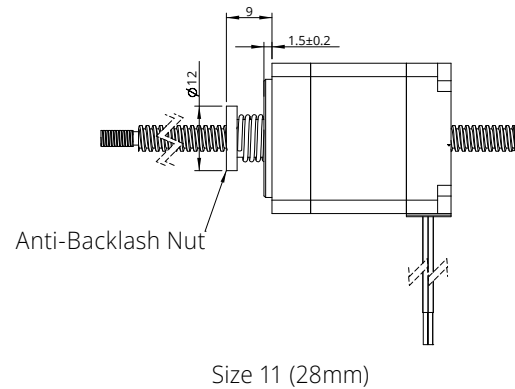
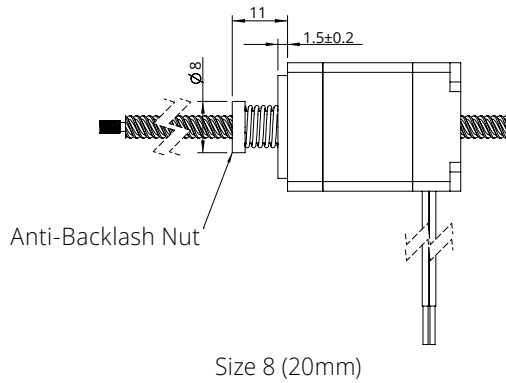

Customized Nut

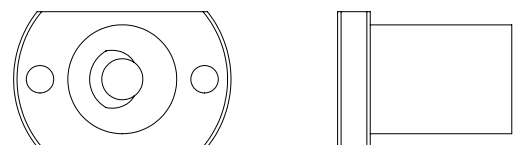
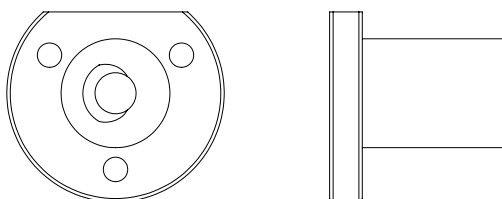

Accessories and Options

Encoder

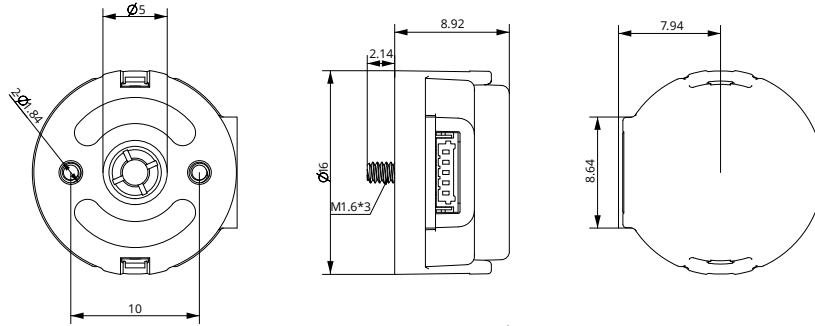

EK 6 Encoder

- EK 6 Encoder (Used for size 6 motors) * No Index

| | | | | | | | | | | |
|---------------------|-----|-----|-----|-----|------|------|------|------|------|------|
| Resolution (CPR) | 250 | 256 | 500 | 512 | 1000 | 1024 | 2000 | 2048 | 4000 | 4096 |
| Single ended output | 0 | 1 | 2 | 3 | 4 | 5 | 6 | 7 | 8 | 9 |

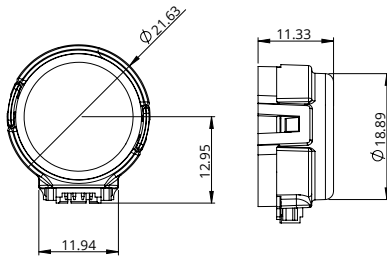

EK 1 Encoder - single ended output

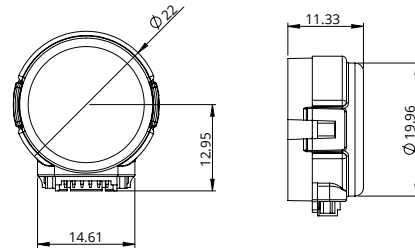

EK 1 Encoder - differential output

- EK 1 Encoder (Used for size 8, 11, 14, 17 motors) * No Index

| | | | | | | | | | | | | | | | | |
|---------------------|-----|-----|-----|-----|-----|-----|-----|-----|-----|-----|-----|-----|------|-----|-----|-----|
| Resolution (CPR) | 100 | 108 | 120 | 125 | 128 | 200 | 250 | 256 | 300 | 360 | 400 | 500 | 1000 | 512 | 720 | 800 |
| Single ended output | 0 | 1 | 2 | 3 | 4 | 5 | 6 | 7 | 8 | 9 | 10 | 11 | 12 | 13 | 14 | 15 |
| Differential output | A | B | C | D | E | F | G | H | I | J | K | L | M | N | O | P |

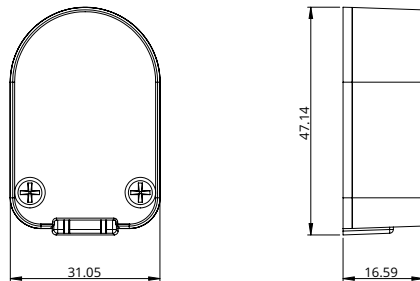

EK 2 Encoder - single ended output

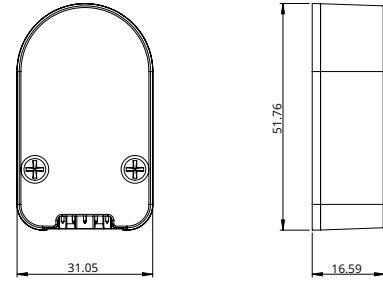

EK 2 Encoder - differential output

- EK 2 Encoder (Used for size 14, 17, 23, 24 motors)

| | | | | | | | | | | | | | | | | | |
|---------------------|----|-----|-----|-----|-----|-----|-----|-----|-----|-----|-----|------|------|------|------|------|------|
| Resolution (CPR) | 50 | 100 | 192 | 200 | 250 | 256 | 360 | 400 | 500 | 720 | 900 | 1000 | 1250 | 2000 | 2500 | 4000 | 5000 |
| Single ended output | 0 | 1 | 2 | 3 | 4 | 5 | 6 | 7 | 8 | 9 | 10 | 11 | 12 | | | | |
| Differential output | A | B | C | D | E | F | G | H | I | J | K | L | M | N | O | P | Q |

Accessories and Options

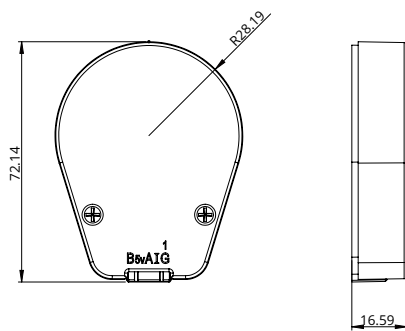

EK 3 Encoder - single ended output

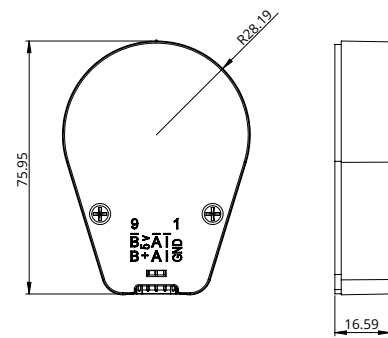

EK 3 Encoder - differential output

- EK 3 Encoder (Used for size 23, 24, 34 motors)

| Resolution (CPR) | 64 | 100 | 200 | 500 | 1000 | 1800 | 2000 | 2500 | 3600 | 4000 | 5000 | 7200 | 8000 | 10000 |
|---------------------|----|-----|-----|-----|------|------|------|------|------|------|------|------|------|-------|
| Single ended output | 0 | 1 | 2 | 3 | 4 | 5 | 6 | 7 | 8 | | | | | |
| Differential output | | A | B | C | D | E | F | G | H | I | J | K | L | M |

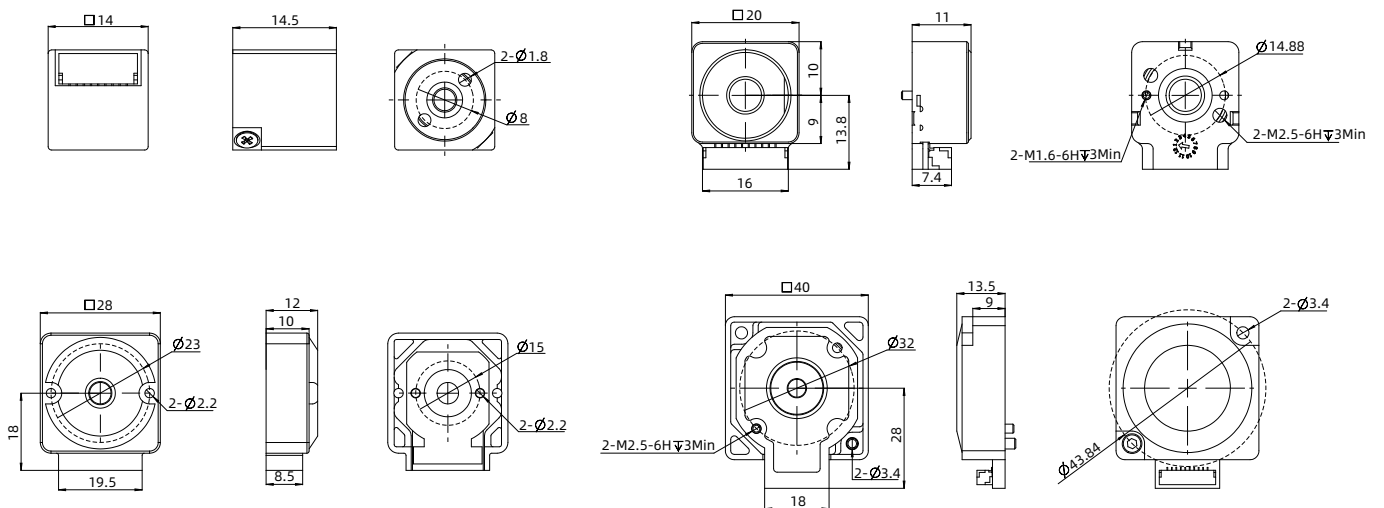

- EK 7 Encoder (Used for size 6, 8, 11, 14, 17, 23, 24 External, Non-Captive motors)

| Resolution (CPR) | - | - | - | 1000 | - | - | 2000 | - | - | - |
|---------------------|---|---|---|------|---|---|------|---|---|---|
| Single ended output | 0 | 1 | 2 | 3 | 4 | 5 | 6 | 7 | 8 | 9 |
| Differential output | A | B | C | D | E | F | G | H | I | J |

Manual Knob

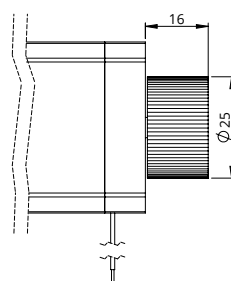

Accessories and Options

Power OFF Brake

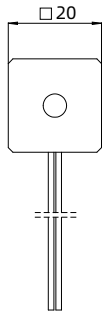

8 (20mm) Series

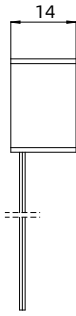

11 (28mm) Series

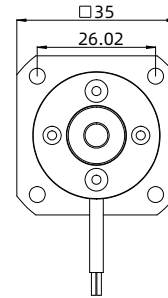
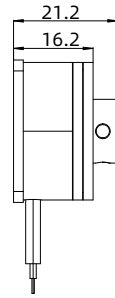
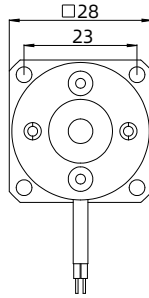

14 (35mm) Series

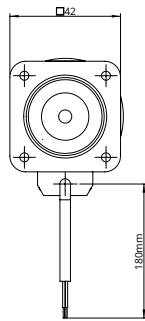
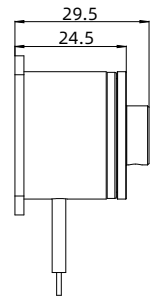

17 (42mm) Series

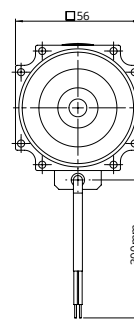
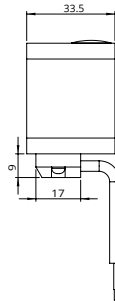

23 (57mm) Series

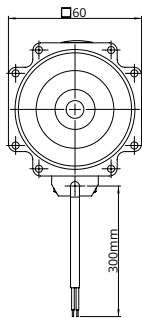
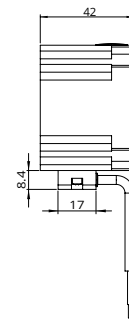

24 (60mm) Series

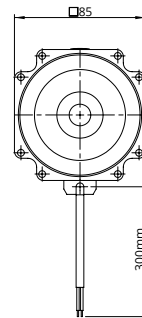
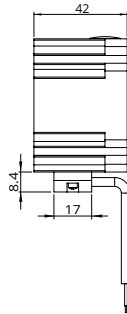

34 (86mm) Series

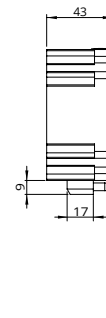

| Series | 8 (20mm) | 11 (28mm) | 14 (35mm) | 17 (42mm) | 23 (57mm) | 24 (60mm) | 34 (86mm) |
|-----------------------|--------------------|------------|-----------|-----------|-----------|-----------|-----------|
| Rated voltage | DC 24V±5% | | | | | | |
| Resistance | 55Ω±10% | 143.7Ω±10% | 217Ω±10% | 145Ω±10% | 141Ω±10% | 141Ω±10% | 69Ω±10% |
| Power | 9.6W | 5.5W | 4W | 5W | 5W | 5W | 12W |
| Hold torque | >0.06N.M | >0.3N.M | >0.3N.M | >0.8N.M | >2N.m | >2N.m | >6N.m |
| Insulation | B | | | | | | |
| Insulation resistance | >100MΩ (DC500V) | | | | | | |
| Dielectric strength | AC 1000V for 1 sec | | | | | | |
| Retraction time | 50ms | | | | | | |
| Release time | 50ms | | | | | | |
| Gyration gap | 1° | | | | | | |
| Emergency brake time | 200 | | | | | | |
| Lifetime | 2,000,000 times | | | | | | |
| Noise level | <60 db | | | | | | |

Installation Guide

■ Precautions for using screw stepper motors

1. The most common installation structures

1) Linear Stepper Motor + Linear Guide

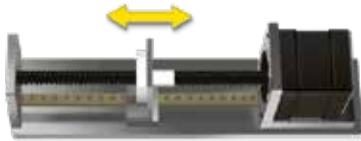

External Lead Screw Linear Actuator + Linear Guide



Non-captive Lead Screw Linear Actuator + Linear Guide

2) Linear Stepper Motor + Guided Rod

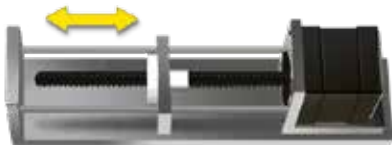

External Lead Screw Linear Actuator + Guided Rod



Non-Captive Lead Screw Linear Actuator + Guided Rod

3) Electric Cylinder (Captive) / Kaptive Lead Screw Linear Actuator Mounted to Load Directly

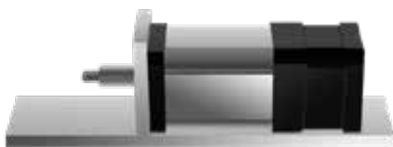

Electric Cylinder (Captive)

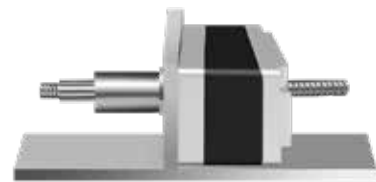

Kaptive

Installation Guide

● Warnings

- 1) Do not dismantle the motor in any case.
- 2) Do not apply radial force to the screw. Do not lift, hang, push or pull the screw during usage or transport.
- 3) Do not add any lubrication to the nut and screw. Protect the grease from being wiped off and no other grease shall be used except those from DINGS'.
- 4) Measures should be taken to protect the lead screw surface from dust.
- 5) Do not drop the motor or screw.
- 6) Do not apply force or tension to the lead wire.
- 7) When using a chopper driver, please set the current (RMS) to the rated current of the motor. Overdriving is not recommended, as it could overheat the motor and cause the winding insulation to melt/burn.
- 8) Operate in ambient temperatures between -20°C to +55°C.
- 9) To maximize life of the system, actual load should be lower than 50% of the recommended load limit. Avoid hitting mechanical hard stops of the system.
- 10) Storage at room temperature with a relative humidity as lower than 75%, clean, well ventilated and free from corrosive gases.

● Typical Electrical Connection

1. General Drive Connection Method

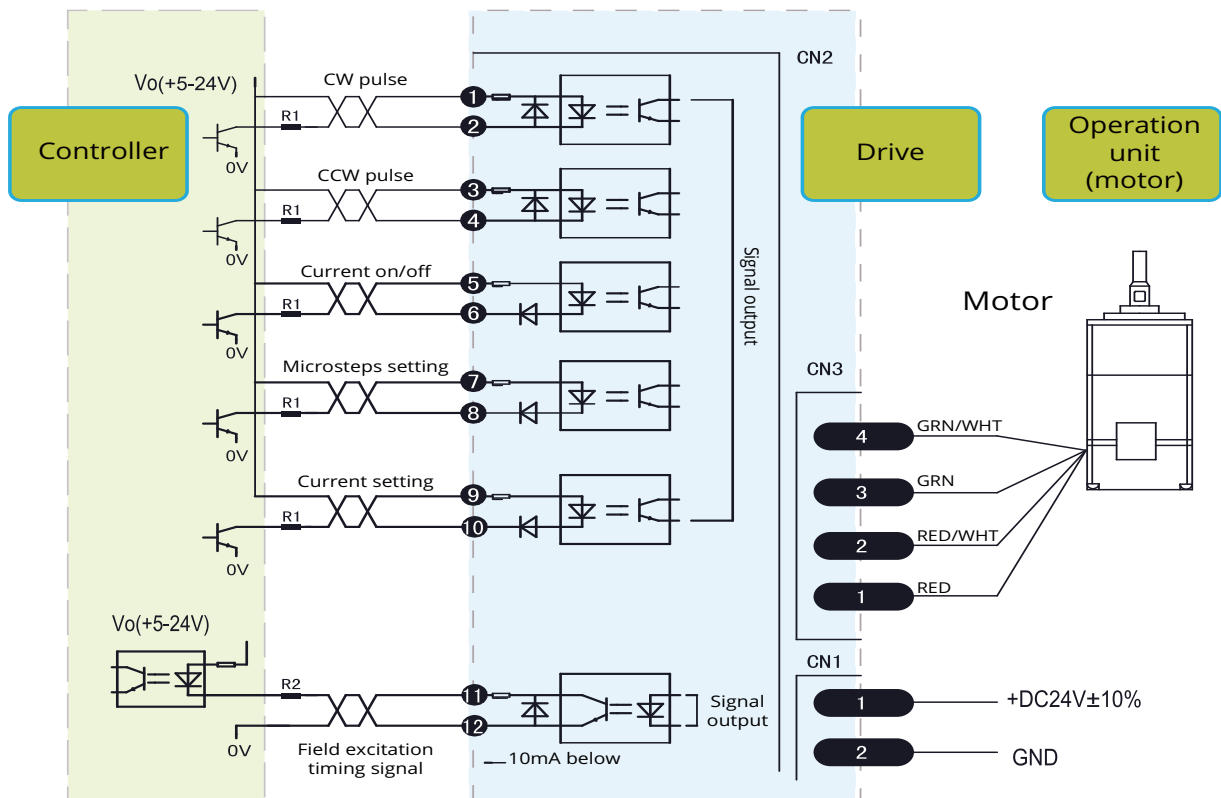

External Nut Strength

| Item | Motor Size | Anti-Backlash Nut | Standard Nut | Triangle / Trimming-cut Nut | Mounting Hole Dimension | Recommended Screw Size Customer Used |
|------|------------|----------------------------|----------------------------|-----------------------------|-------------------------|--------------------------------------|
| | | Installation Torque / Max. | Installation Torque / Max. | Installation Torque / Max. | | |
| 1 | 14 mm | 0.8kgf.cm | 1.0kgf.cm | | Ø2.6/Ø3.2 | M2.5 or M3 and smaller |
| 2 | 20 mm | 0.8kgf.cm | 1.0kgf.cm | | Ø2.6/Ø3.2 | M2.5 or M3 and smaller |
| 3 | 28 mm | 0.8kgf.cm | 4.0kgf.cm | | Ø2.6/Ø3.2 | M2.5 or M3 and smaller |
| 4 | 35/42 mm | 4.0kgf.cm | 5.5kgf.cm | 5.5kgf.cm | Ø3.2 | M3 and smaller |
| 5 | 57/60 mm | 6.0kgf.cm | 6.0kgf.cm | | Ø3.5/Ø5.1 | M3 or M5 and smaller |
| 6 | 86 mm | | | 18kgf.cm | Ø7.0/Ø8.0 | M6 and smaller |

Trouble Shooting

| Common Failure | Cause Analysis | Processing Methods |
|--|---|--|
| Motor not Running | Poor Connection | Re-connection |
| | Driver Alarm | Power Off and Re-boot after checking |
| | Actuator Stuck | Remove load, ensure actuator operates smoothly without load |
| | Motor winding or insulation damaged | Contact DINGS' for maintenance |
| Abnormal Operation After Starting Up | Resonance | Enhance microsteps to change travel speed |
| | Lead Screw Bend | Contact DINGS' for maintenance |
| | Phase Loss | Contact DINGS' for maintenance |
| Vibration, Noise | Low-Frequency Vibration | Adjust driver microsteps to change travel speed to avoid resonance |
| | Phase Loss | Contact DINGS' for maintenance |
| Abnormal Heating | Over Current | Regulate current value to achieve proper rating range |
| | Over Supply-voltage | Reduce supply-voltage |
| | Extended period of holding | The holding current should be halved or adjusted to smaller value |
| Step Loss | Overload on the Load Side | Reduce load or re-selection |
| | No frequency raising or lowering when programming | When motor starts, it needs to be accelerated from low to high |
| Insufficient Thrust | Driver Failure | Repair or replace driver |
| | Load is too high | Reduce load or resize actuator |
| | Damaged Nut | Contact DINGS' for maintenance |
| Lead Screw Bend or Runout at the End of Lead Screw | Damage in Transportation or Improper Installation or Improper Operation | Contact DINGS' for maintenance |
| Other Failures | | Contact DINGS' for maintenance |

DINGS'

Precision Motion Specialist

Headquarter , CHINA

Jiangsu DINGS' Intelligent Control Technology Co., LTD

No.2850 Luheng Road, Changzhou Economic Development Zone, Jiangsu Province, China

Phone : +86-519-85177826

Fax : +86-519-85177807

E-mail : info@dingsmotion.com

www.dingsmotion.com

Shenzhen Office

Room 1105, Block C, CIMC industry demonstration park, Qiaoming Road, Guangming district, Shenzhen City

E-mail : info@dingsmotion.com

International Office

DINGS' Motion USA

355 Cochrane Circle Morgan Hill, CA 95037

Phone : +1-408-612-4970

E-mail : sales@dingsmotionusa.com

www.dingsmotionusa.com

DINGS' KOREA Co., Ltd

C-702, 158, Haneulmaeul-ro, Ilsandong-gu, Goyang-si, Gyeonggi-do, Republic of Korea

Phone : +82-31-994-0755

Fax : +82-70-4325-0755

E-mail : daniel@dingsmotion.com

www.dingsmotion.kr

DINGS' JAPAN

101, 2-27-18, Nishi-kojiya, Ota-ku, Tokyo 144-0034 JAPAN

Phone : +81-3-6811-1335

E-mail : tsukahara@dingsmotion.com

www.dingsmotion.com

- This catalog is the sole property of DINGS' and without the written authorization of DINGS', any copy or forwarding is prohibited.
- DINGS' reserves the right to make changes without further notification to any products herein to improve the reliability, function or design.
- DINGS' reserves the final interpretation.